

castle may be rotated in steps of 45° when assembled to lid

inner window aperture
outer window aperture

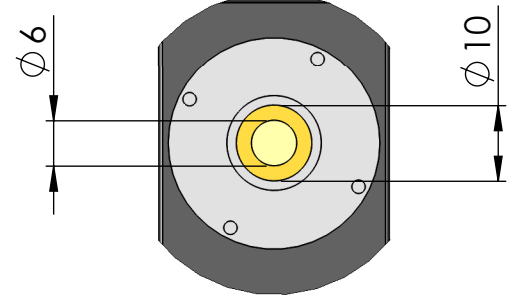

DETAIL B
SCALE 1 : 1

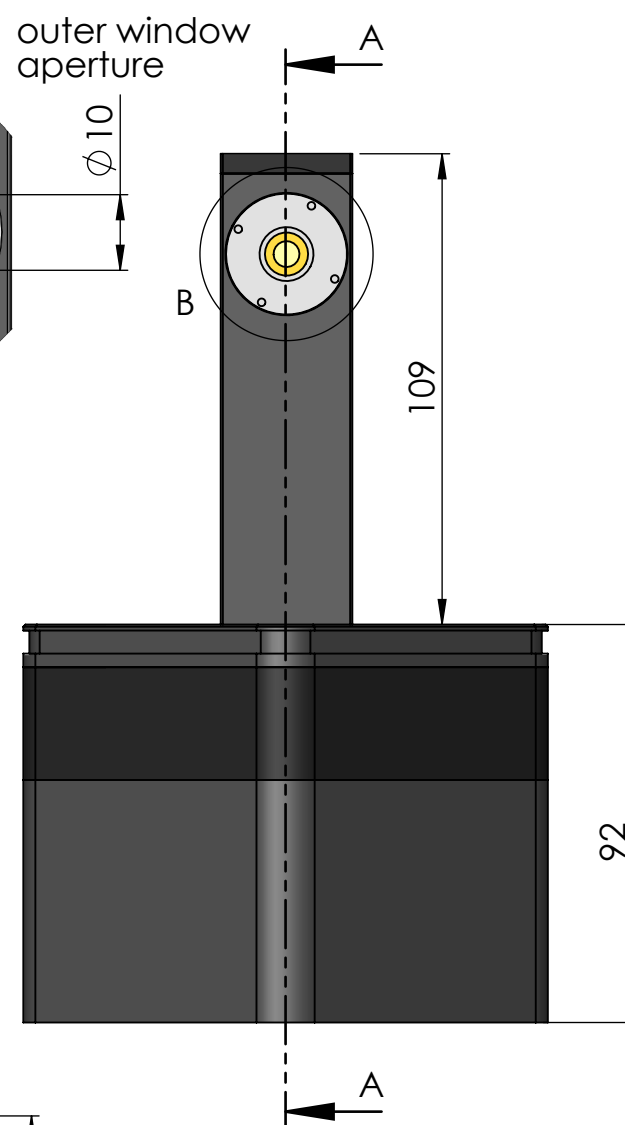

typical distance from outer face of outer window to inner face of inner window ≈1.5mm

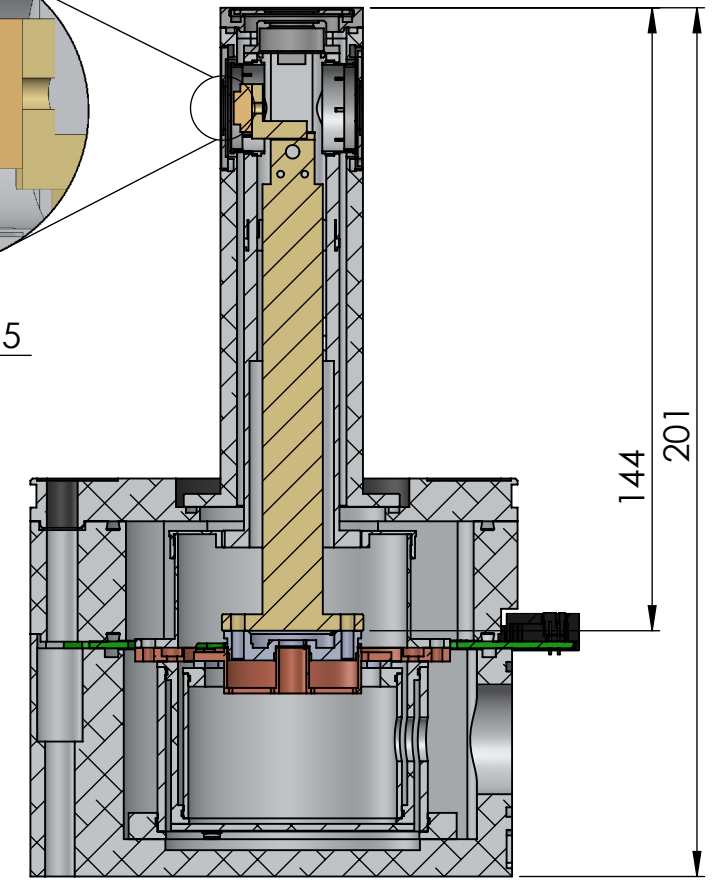
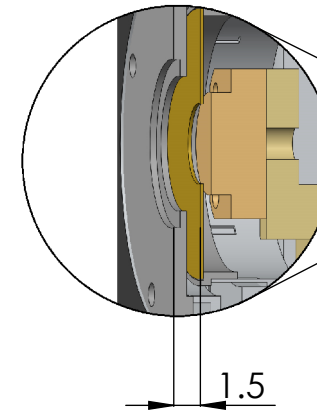

SECTION A-A
SCALE 1 : 1.75

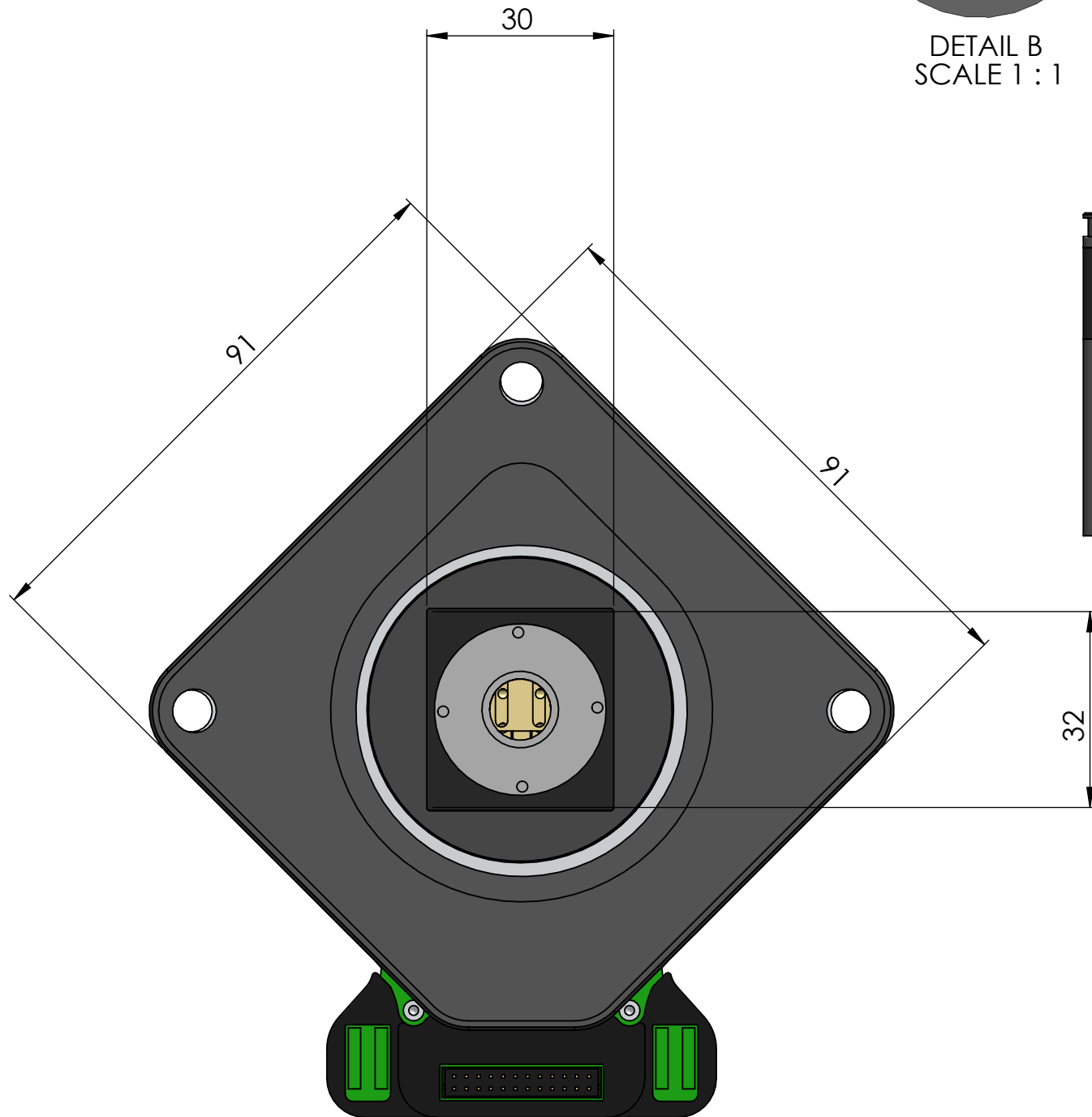

DIMENSIONS ARE IN MILLIMETERS
TOLERANCES ARE

DECIMALS	FRACTIONS	ANGLES
.X ±.05	.XXX ±.005	±1/64
.XX ±.01	.XXXX ±.0005	±1°
		-.0000

MATERIAL

FINISH

1	4	5	6
---	---	---	---

DO NOT SCALE DRAWING
PREPARED IN SOLIDWORKS 2009

APPROVALS	DATE
DRAWN JAMES L	
CHKD	
REL	
NEXT ASSY	USED ON

TALL RECTANGULAR CASTLE DIMENSIONS			
FILENAME: 4200-100 tall rectangular housing.SLDDRW			
MONTANA INSTRUMENTS CORPORATION BOZEMAN, MT			
SIZE	CAGE	DRAWING NO.	
B		DOC-152	
SCALE	REV	REA NO.	SHEET
1:5			1 OF 1