

Subject
2005-2007 Ford 6.8L V10 Throttle Control Diagnostics Except "G" Kit

## System or Parts affected

<b>Underhood70 V900081</b>
<ul style="list-style-type: none"> <li>• Throttle Control P/N# 3560094</li> </ul>

## Related information

This throttle module ties into the Ford SEIC system (Stationary Elevated Idle Control), please see Ford bulletin for diagnostic information:

Ford bulletin: [Q-108](#)



## Before you start

Most Throttle Control issues are due to poor electrical connections and/or poor grounding. VMAC recommends that all electrical connections (with the exception of the clutch connector in the engine bay) be soldered and shrink wrapped. We do not recommend using bullet connectors.

Figure 1 shows the location of the SEIC Blunt Cut Wire Harness where the majority of the Throttle Control connections are made.

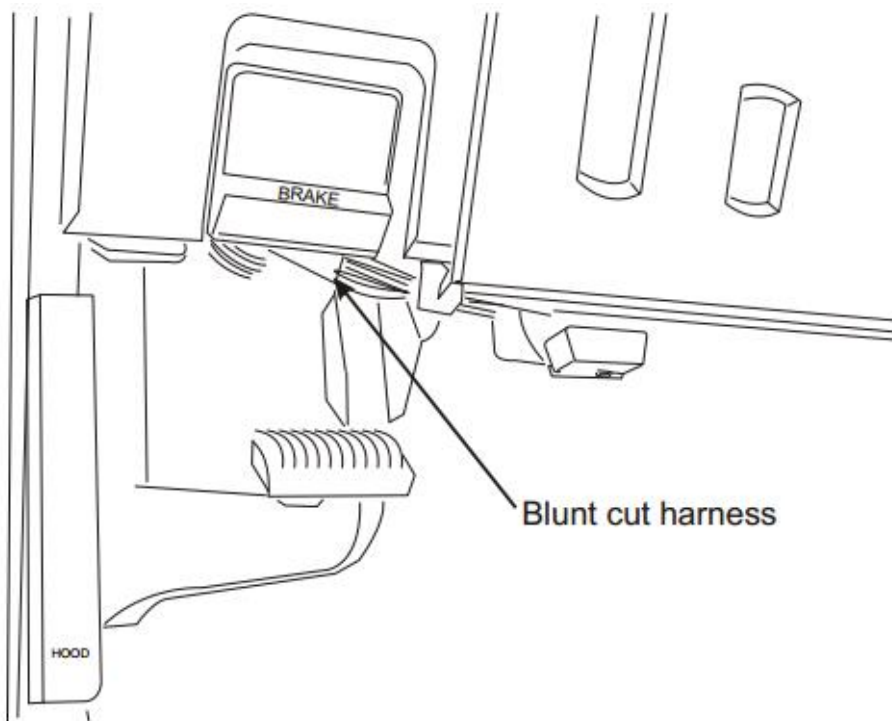

Figure 1

Document	Version	Department	Revision Details	Revised by	Tech	Engineering	Implemented
EXT-VRTC-006	A	Tech	Document Release	SP 30 Jul 2015	DB 30 Jul 2015	N/A	30 Jul 2015

**Subject**  
2005-2007 Ford 6.8L V10 Throttle Control Diagnostics Except "G" Kit

**Overview**

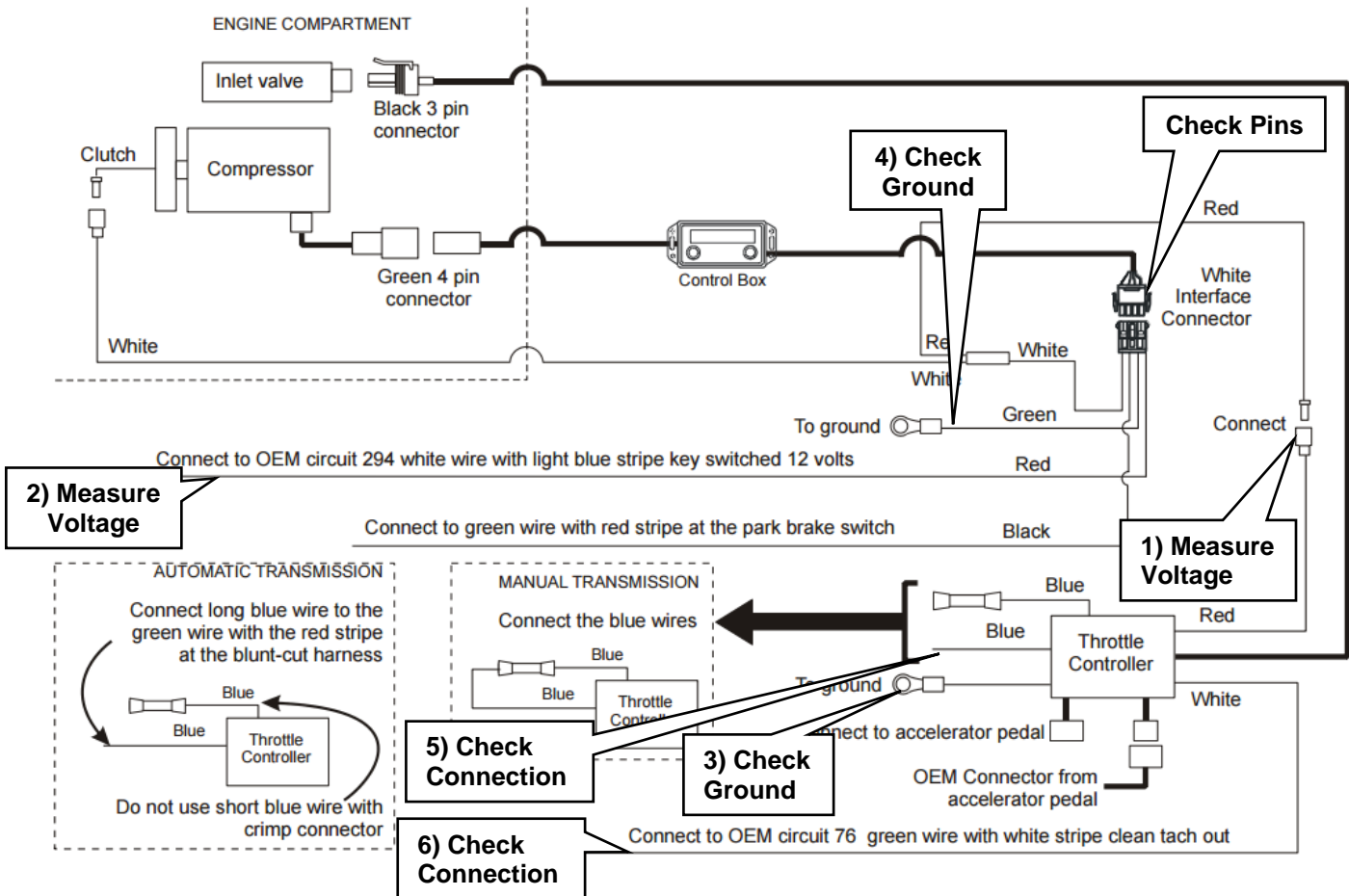

Figure 2

**Isolate Issues:**

- 1) With the engine off, key in the run position and park brake applied, measure the voltage to the RED throttle control +12V wire (Should be +12V DC). This will be powered when compressor is turned on.
- 2) With the engine off, key in the run position and park brake applied, measure voltage on the RED wire running to the WHITE interface connector (Should be +12V DC). This will be powered when key switch is on.
- 3) Measure the resistance of the GREEN ground connection from the throttle controller to the vehicle battery's negative terminal. This reading should be less than 1 ohm.
- 4) Measure resistance between WHITE interface connector ground terminal and battery negative terminal. This reading should be less than 1 ohm.
- 5) Check the BLUE wire from the throttle controller, ensure it is a good soldered connection to the GREEN with RED stripe wire in the blunt cut bundle.
- 6) Check the WHITE wire from the throttle controller to the "clean tach out" circuit 76 (see wiring diagram) at the blunt-cut harness. Ensure this is a good soldered connection.

Document	Version	Department	Revision Details	Revised by	Tech	Engineering	Implemented
EXT-VRTC-006	A	Tech	Document Release	SP 30 Jul 2015	DB 30 Jul 2015	N/A	30 Jul 2015