

Cradle to take  
2632 Brute bin

1-Phase, 3-Phase or battery  
power source

Dual handed controls

125D Resilex Castors

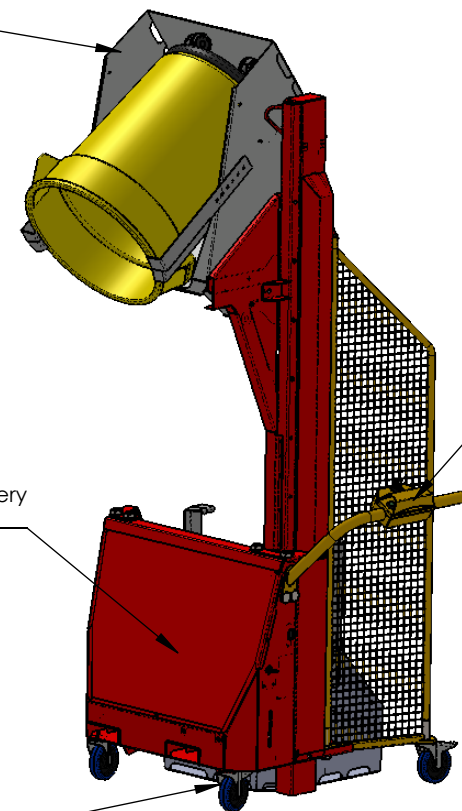
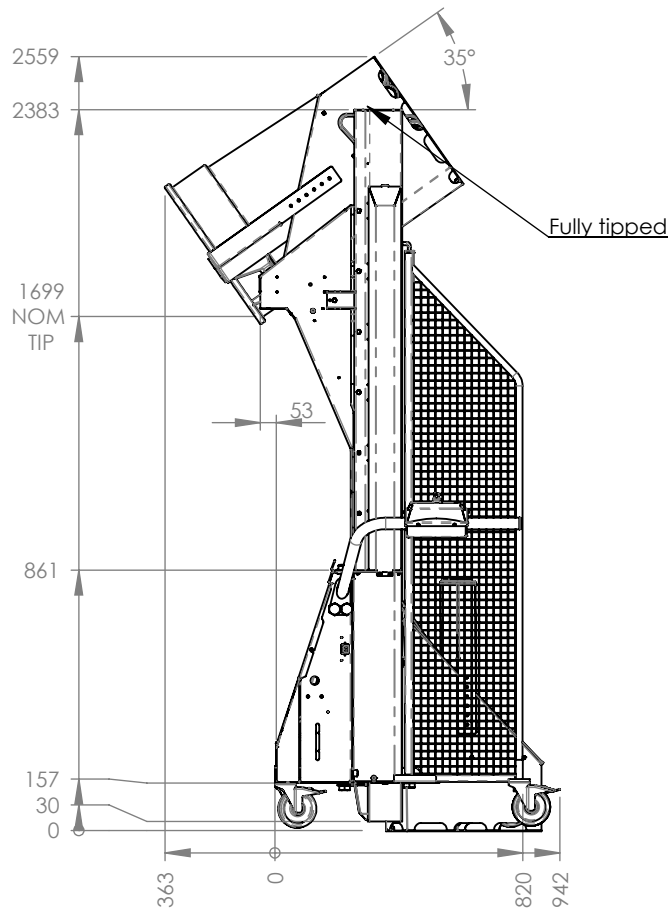

Signed as an official confirmation of correct mechanical specifications and dimensions, for model 9510 Multi tip -240-1600 assy

Date	Tuesday, 6 December 2016
Revision	A Original
Lead time	4-8 weeks from receipt of official confirmation of specifications
Tipping height correct	Yes/No (Circle one)
Overall dimensions correct	Yes/No (Circle one)
Guarding correct	Yes/No (Circle one)
Name	
Signature	

B	2015 Revision
A	Original
REV	DESCRIPTION & DATE