

Subject
CSX Standalone Throttle 2020 - 2021 GM 6.6 L Gas

SYSTEM OR PARTS AFFECTED

- The Digital Throttle Control (DTC) used in the this system is VMAC P/N: 3560271.

OVERVIEW

- VMAC's warranty Data Base should indicate that the DTC has been sold to CSX as a Standalone unit.
- The warranty is standard 1 year parts sale.

NORMAL OPERATION

When the clutch pump is enabled, the DTC is powered and goes to the speed selected:

- Speed 1 (return signal should be 4.8 V).
- Speed 2 (return signal should be 3.28 V).

TROUBLE SHOOTING



This is not a "standard" VMAC system and as such, VMAC's technical support is limited to the components below the dashed line.

- The DTC may indicate "Bad Pressure Sensor" (STATUS LED blinking red, 3 pulses).
- Perform standard DTC troubleshooting (i.e. check interlocks, wiring etc.).
- Confirm: good ground connections.
- Confirm 5 V on the red wire on the pressure transducer harness.
- Confirm the voltage on the green wire (return signal voltage) in the pressure transducer harness is within the specification listed above.

Version	Document	Department	Revision Details	Author	Reviewed by		Implemented
					Tech.	Eng.	
A	EXT-VRTC- 011	Tech	Document Release	MSP	DSB/CL	AJH	26 May 2021

Subject
CSX Standalone Throttle 2020 - 2021 GM 6.6 L Gas

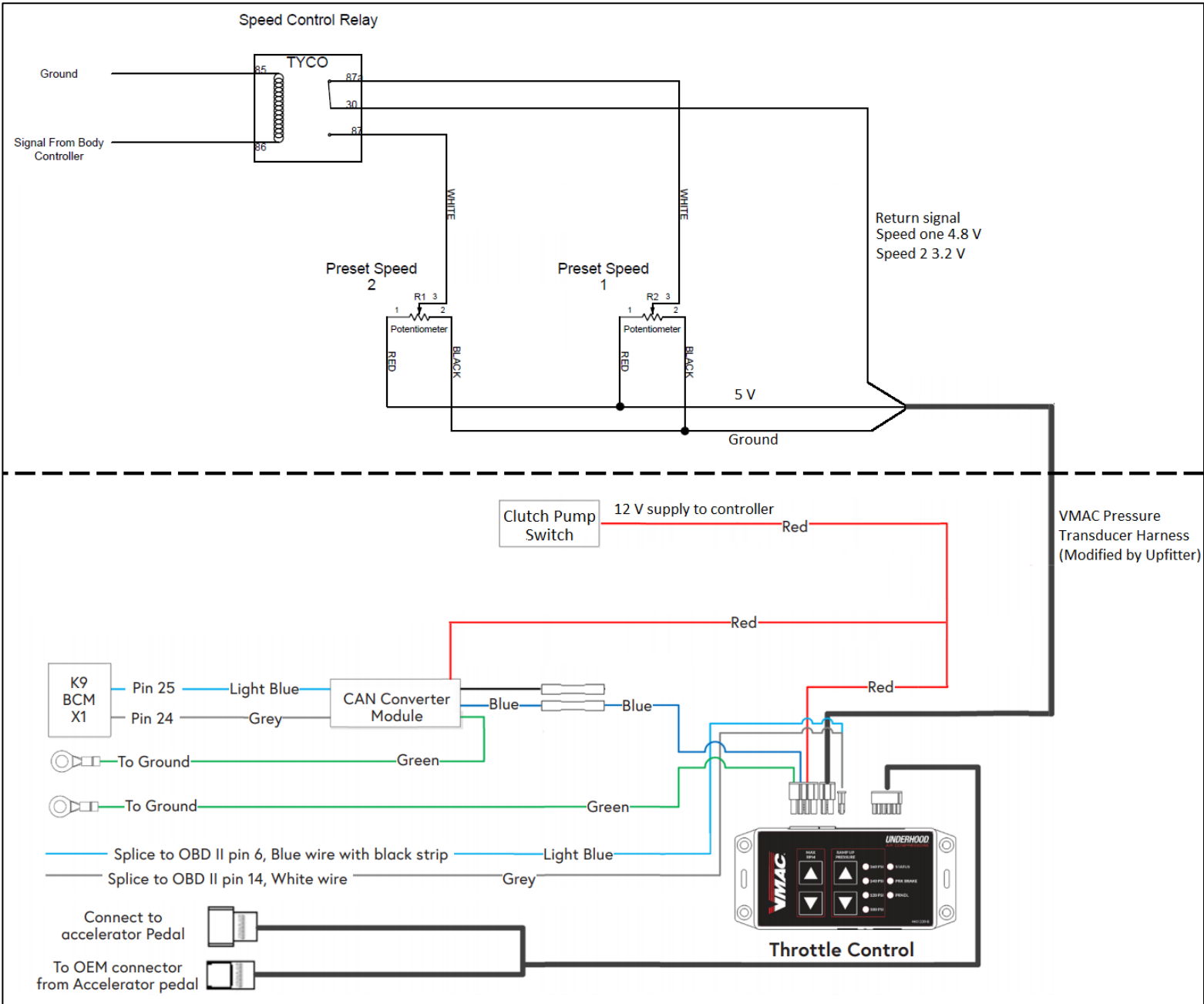

Version	Document	Department	Revision Details	Author	Reviewed by		Implemented
					Tech.	Eng.	
A	EXT-VRTC- 011	Tech	Document Release	MSP	DSB/CL	AJH	26 May 2021