

Airworthiness Directive

▼ Federal Register Information

This information is not available.

▼ Header Information

DEPARTMENT OF TRANSPORTATION

Federal Aviation Administration

14 CFR Part 39

AD 48-04-02

Airworthiness Directives; Aeronca Model 7AC, 11BC and 11AC Airplanes
PDF Copy (If Available):

▼ Preamble Information

AGENCY: Federal Aviation Administration, DOT

▼ Regulatory Information

48-04-02 AERONCA: Applies to 7AC Serial Numbers 7AC-1 Through 7AC-7129; 11BC Serial Numbers 11BC-1 Through 11BC-173; and 11AC Serial Numbers 11AC-1 and Up.

Compliance required by March 1, 1948.

Inspect the wing leading edge for buckled nose ribs or loose PK screws by pressing leading edge skin with hand to nose ribs. If the skin can be depressed beyond the normal wing contour, other than the extreme nose radius, indicated by section A-A in

Figure 1, the fabric should be cut open on the bottom surface just forward of the front spar for thorough inspection. Item No. 1 below should be accomplished on all wings whether damage has occurred or not, whereas item No. 2 pertains only to damaged ribs found in the above inspection. Repair need not be made if buckling is confined to area forward of section A-A of Figure 1.

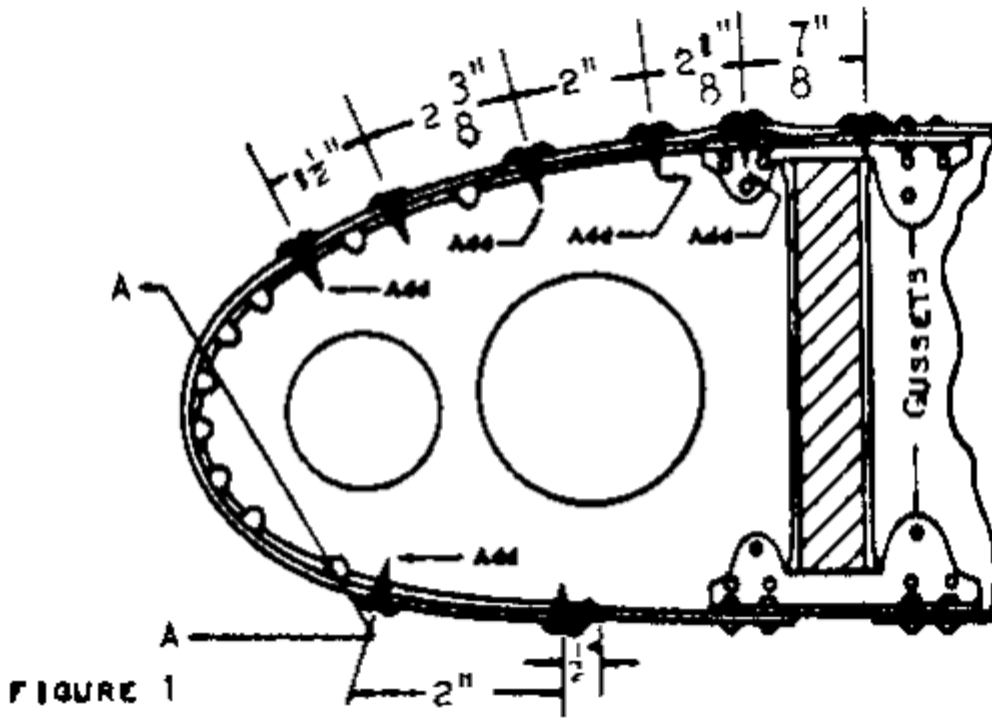

1. To help prevent further failures of the nose ribs five additional No. 4 x 1/4 PK screws or, as an alternate, Cherry CR163-4-2 rivets or equivalent are to be installed in all nose ribs. Four PK screws or rivets are to be installed on the top surface and one PK screw or rivet is to be installed in the bottom as shown in Figure 1. Apply dope liberally under the PK screw head before tightening. It is not necessary to remove the fabric to accomplish this modification.

2. Damaged ribs should be cut away at the top and bottom of spar. The new nose ribs are installed by means of two gussets on the side of the ribs as shown in Figure 1. Factory kits, Aeronca P/N 5-185-2 and 5-190-2, are to be used.

(Aeronca Helps and Hints No. 17 with three supplements thereto covers this same subject.)

▼ **Footer Information**

▼ **Comments**

