

Ercoupe MEMORANDUM

ERCOUPE
SERVICE
MEMORANDUM

No. **42**

SUBJECT: Rerouting of Fuel Pump Lines

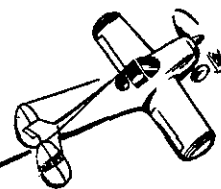

Failure of a fuel pump pressure line, due to chafing on the nose cowl has resulted in a change in the routing of the fuel pump lines. This change was effected at serial number 3643. Ercoupes up to and including serial number 3642 having fuel pumps incorporating metal filter bowl and bearing the AC part number 1539076 on the mounting flange, will be affected by this memorandum. The fuel pumps which use a glass filter bowl (AC 1523843 and AC 15339051) are not affected. It is recommended that this memorandum be complied with at the next 100 hour check because there is a possibility of an eventual failure of this line if not modified. Inspection at each 25 hour check for chafing should be made until modification is effected.

1. Preliminary Operations:

a. Remove the following general parts:

1. Engine Top and Side Cowling Assembly (415-40422 and 415-40090 L/R).
2. Propeller Spinner (415-40593 or 415-40594). See Memo. No. 28.
3. Propeller (415-40500-2).
4. Engine Nose Cowl (415-40451).

2. Removal of Right Front Engine Cooling Baffle and Fuel Pump:

a. Remove cooling baffle and fuel pump as follows:

1. Disconnect both fuel pump hoses after removing clamps.
2. Remove cooling baffle after removing front pump mounting nut and washer.
3. Remove fuel pump after removing rear pump mounting nut and washer.

3. Disassembly and Reworking of Fuel Pump:

a. Disassemble and rework fuel pump as follows: (Ref. Page 3, Fig. 2.)

1. Cut safety wire and remove the six screws joining upper and lower halves. There will be considerable spring pressure when removing the last screw.
2. Check the condition of the diaphragm while pump is disassembled. All fuel pump parts necessary for repair are available from the Continental Motors Corporation, and AC Automotive Service Stations.
3. Rotate top of pump 120° clockwise (two screw holes from the original position).
4. Reassemble pump halves with the six original lockwashers and screws.
5. Safety screws with brass safety wire, American Steel & Wire Gage No. 18 (.041 dia.)
6. Replace pump inlet port fitting with AN842-4D elbow, using Parker Sealube (6PE) on threads.
7. Replace pump outlet port fitting with 415-48101-40 elbow having 1/16" restriction, using Parker Sealube (6PE) on threads.

4. Reworking of Right Front Engine Cooling Baffle: (Ref. Page 3, Fig. 1)

a. Rework cooling baffle as follows:

1. Mark two holes in baffle as illustrated in Fig. 1, Page 3.
2. Drill two 3/4" diameter holes at the above marks.
3. Install two elastic grommets (AN931-9-13) into the new holes.
4. Snap button plug (415-40589-1) into the extra unused hole.

5. Installation of Fuel Pump and Right Front Engine Cooling Baffle:

- a. Install fuel pump and cooling baffle as follows:
 - 1. Insert fuel pump hoses through respective holes, with grommets, in cooling baffle.
 - 2. Install fuel pump being certain that wobble arm lays on top of cam-lobe inside of crankcase.
 - 3. Install nut and washer on rear pump mounting stud.
 - 4. Place cooling baffle, and attach to front pump mounting stud with nut and washer.
 - 5. Install Palnuts on both pump mounting studs after the nuts are tightened.
 - 6. Shorten outlet hose (415-48201-3) as necessary to permit strain-free installation.
 - 7. Install fuel pump hoses (415-48201-3) onto respective elbows.

- 8. Secure with two hose clamps (AN746-4) and safety clamps with brass safety wire, American Steel & Wire gage No. 18 (.041 dia.)

6. Installation of General Parts:

- a. Install the following general parts:
 - 1. Engine Nose Cowl (415-40451).
 - 2. Propeller. If crankshaft in engine is the flange type, torque propeller hub bolts (125 175 inch/pounds), and then check track. The maximum track tolerance is 1/16". Safety hub bolts with brass safety wire, American Steel & Wire gage No. 23 (.051 dia.)
 - 3. Propeller Spinner (415-40923).
 - 4. Engine top and side cowling assembly.

Fuel Pump Modification Service Kit No. 7 contains the following items:

<i>Nomenclature</i>	<i>Part Number</i>	<i>Qty.</i>
Elbow, Pipe thread and hose 45° 1/16" I.D. Restriction.....	415-48101-40	1
Elbow, Pipe thread and hose 90° (415-48101-41).....	AN842-4D	1
Plug, Button	415-40589-1	1
Grommet, Elastic (415-40400-55).....	AN931-9-13	2

The Kit may be purchased through Ercoupe Dealers at a price of \$1.75 list.

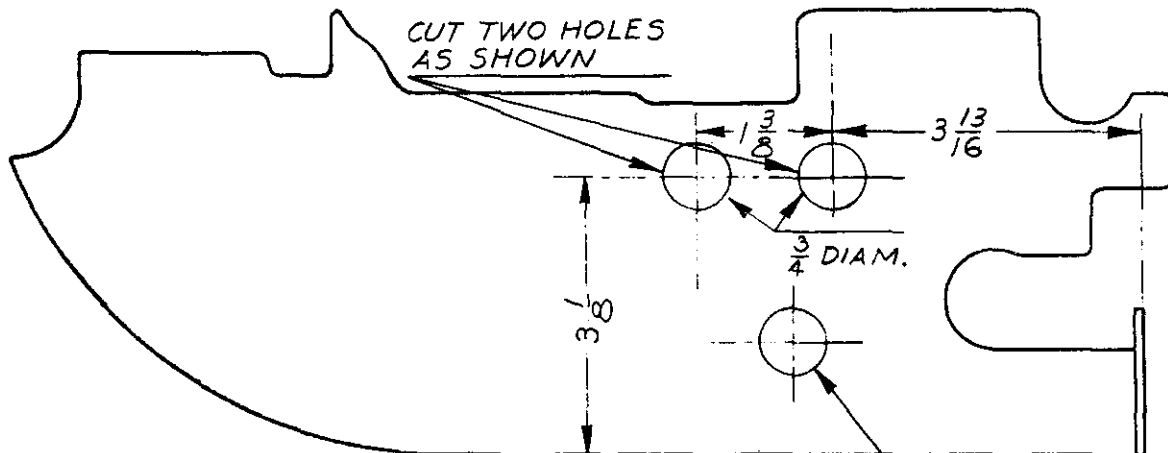

INSERT BUTTON PLUG
(PART No. 415-40589-1)
IN EXISTING HOLE



MODIFICATION OF RIGHT FRONT
ENGINE COOLING BAFFLE
(PART No 415-40403)

(For replacement, order Engine Cooling Baffle (Part
No. 415-40569))

FIG. 1

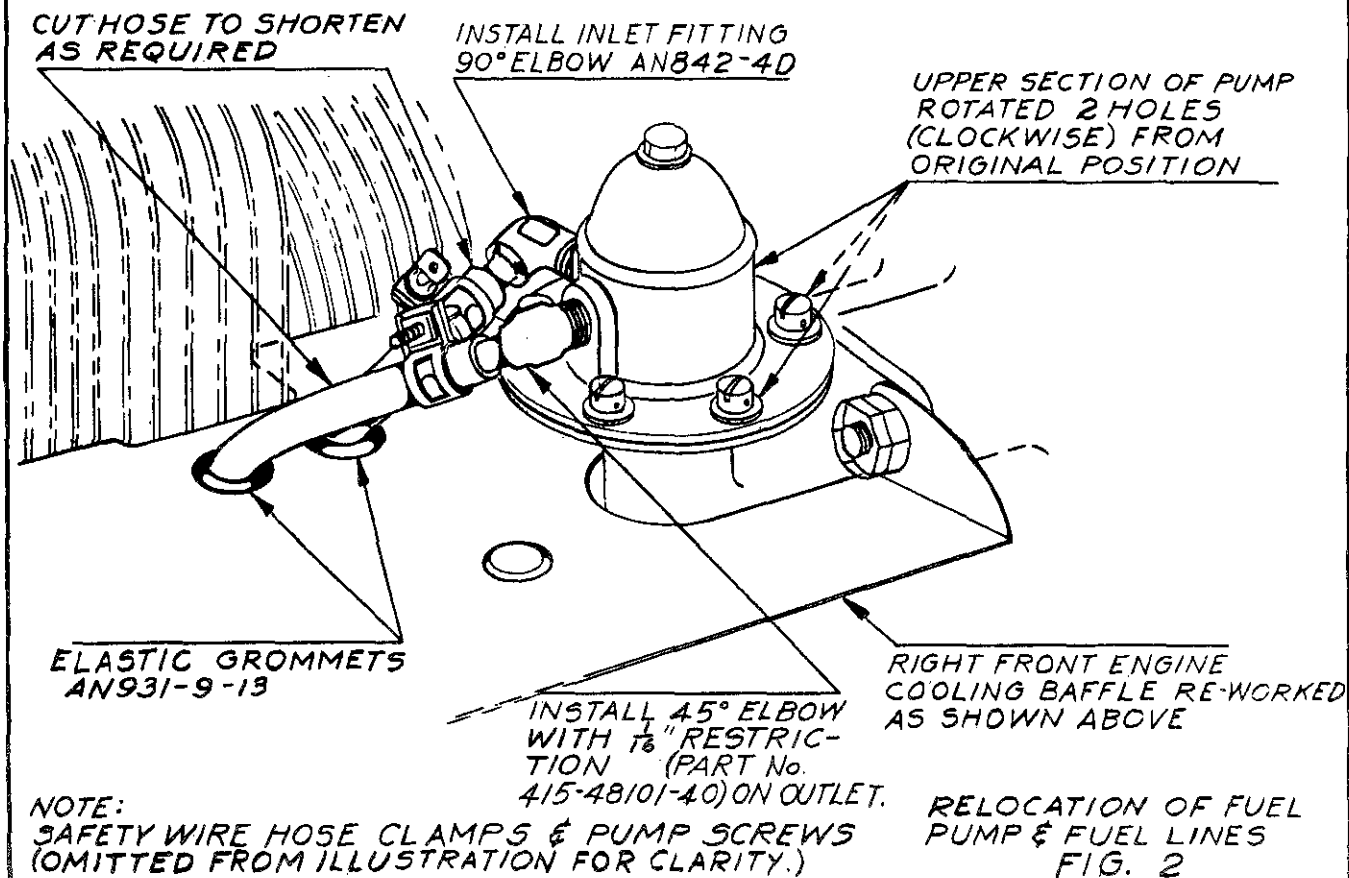

RELOCATION OF FUEL
PUMP & FUEL LINES
FIG. 2