

UNIVAIR AIRCRAFT CORPORATION

TOLL FREE ORDER # 1 (888) 433-5433

PLANT, OFFICES, AND WAREHOUSES: 2500 HIMALAYA ROAD, AURORA, CO 80011-8156

INFO TELEPHONE: (303) 375-8882

FAX NUMBERS: (800) 457-7811 or (303) 375-8888

e-mail info@univair.com web site www.univair.com

UNIVAIR®

ERCOUPE SERVICE BULLETIN NO. 34

ELEVATOR CONTROL HORN INSPECTION

Engineering Aspects of this Service Bulletin are FAA Approved

DATE: January 4, 2013 Revision None

SUBJECT: Visual inspection of the steel elevator control horn and its mating aluminum channel for evidence of corrosion.

MODELS AFFECTED: Ercoupe 415-C, 415-CD, 415-D or other Ercoupe models with a continuous trailing edge elevator.

COMPLIANCE: Initial inspection required within the next 12 calendar months or annual inspection, whichever occurs first. Recurrent inspections every five years or whenever additional corrosion is suspected, whichever comes first.

Univair Aircraft Corporation Considers Compliance with this Service Bulletin Mandatory.

PERSONNEL: **IMPORTANT:** All work and inspections required by this Service Bulletin are to be performed by a properly rated and equipped certified mechanic or repair station with experience in the work, use of equipment, inspections, and repairs listed.

STATEMENT OF DIFFICULTY:

There was a field report of dissimilar metal corrosion found on an Ercoupe 415-C. The area of corrosion occurred where the steel elevator control horn attaches to the



aluminum lateral stiffener located within the elevator assembly. Dissimilar metal corrosion is a concern of aircraft designed and manufactured during this era.

This particular elevator assembly, Ercoupe part number 415-22001, is easily identifiable as the style with a continuous (compared to the split-type) trailing edge. It was specific to Ercoupe models 415-C, 415-CD, and 415-D, serial numbers 1 – 4868. Later model Ercoupe series aircraft using an aluminum elevator control horn in conjunction with the split-type trailing edge are not subject to this Service Bulletin.

As originally designed, this area of the elevator has no adequate means of internal inspection. Any compromise in the steel or aluminum can only be detected by removing the aluminum elevator skins. However, the addition of several small inspection covers, specifically designed for this situation, provides for any necessary inspection of this area.

Univair has determined that two 1.56 diameter holes and one trapezoidal shaped hole located at the center of the bottom elevator skin will provide adequate inspection coverage of the attachment area of the steel elevator control horn. See Univair drawing 415-22013 INSP for layout dimensions of inspection holes.

Procedure:

The following procedure is used to locate and install the inspection openings in the lower elevator skin:

1. Remove 415-31039 tail fairing assembly from airplane.
2. Disconnect trim spring from elevator horn.
3. Disconnect elevator linkage from elevator horn.

The elevator should now be free to lift up and mark inspection access hole locations as detailed on drawing 415-22013 INSP.

*NOTE: If the subject aircraft has been modified with the later style elevator trim tab using the wire and housing control, care should be taken so that the housing is not bent or kinked. Excessive movement of the elevator could cause damage to the control cable, in which case, replacement may be necessary.

4. Cut two 1.56 diameter holes in lower elevator skin aft of the aluminum stiffener per drawing 415-22013 INSP. Locate the inspection hole forward of the aluminum stiffener using template 415-22001-105, per drawing 415-22013 INSP. Locate and drill #17 holes as required.

5. Apply corrosion protection to the newly exposed edges of the cutouts and holes to prevent corrosion, per AC43.13-1B, Chapter 6, Section 3, "Corrosion Protection Measures for Basic Materials".
6. Inspect 415-22016 elevator control horn and the area where it attaches to the 415-22006 aluminum stiffener. Inspect both the forward and aft sides of the aluminum stiffener. See FAA Advisory Circular AC43.13-1B for guidelines concerning dissimilar metal corrosion.
7. If corrosion is found, repair and/or replace parts as necessary. Replacement parts are available for purchase from Univair.
8. When inspection is complete, install 294667 clipnuts and 415-22001-101 and 415-22001-103 plates over their respective openings and secure with MS35206-230 screws.
9. Connect elevator linkage to elevator horn.
10. Connect trim spring to elevator horn, if necessary.
11. Reinstall tail fairing assembly.
12. After this has been accomplished, with the elevator in its full down position, check clearance between the head of the MS35206-230 machine screws and the 415-31039 tail fairing. Verify that at least a .063 gap exists between the two.
13. Make appropriate logbook entry stating that Ercoupe Service Bulletin 34 has been complied with.

CONTINUED MAINTENANCE:

Verify the security of the MS35206-230 machine screws and 294667 clipnuts every 100 hours or during annual inspection, whichever occurs first.

INFORMATION AND PARTS AVAILABILITY:

Contact Univair Aircraft Corporation for availability of Ercoupe Service Kit SK-82, which contains the necessary template, inspection plates, screws, and clipnuts required to comply with this service bulletin.

NOTE: SK-82 contains no corrosion protection measures as specified in Step 5, above.

NOTES:

1. LOCATE .173 HOLES AND FORWARD INSPECTION HOLE WITH 415-22001-105 TEMPLATE. ALIGN FORWARD EDGE OF TEMPLATE WITH SEAM.
2. ORIENT LEFT SIDE 415-22001-101 SUCH THAT .173 HOLES AND 294667 CLIPNUTS CLEAR CENTER RIB FLANGE. CLIPNUTS NOT SHOWN AT 415-22001-101 LOCATIONS.
3. VIEW IS OF LOWER ELEVATOR SKIN. LEFT OUTBOARD IS TO THE RIGHT.

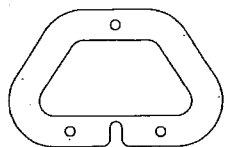
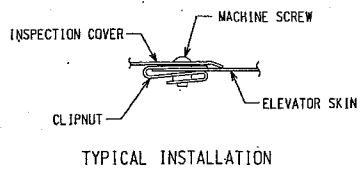

415-22001-105

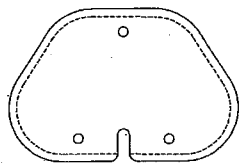

415-22001-103

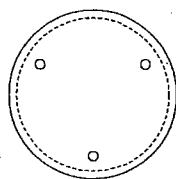

415-22001-101

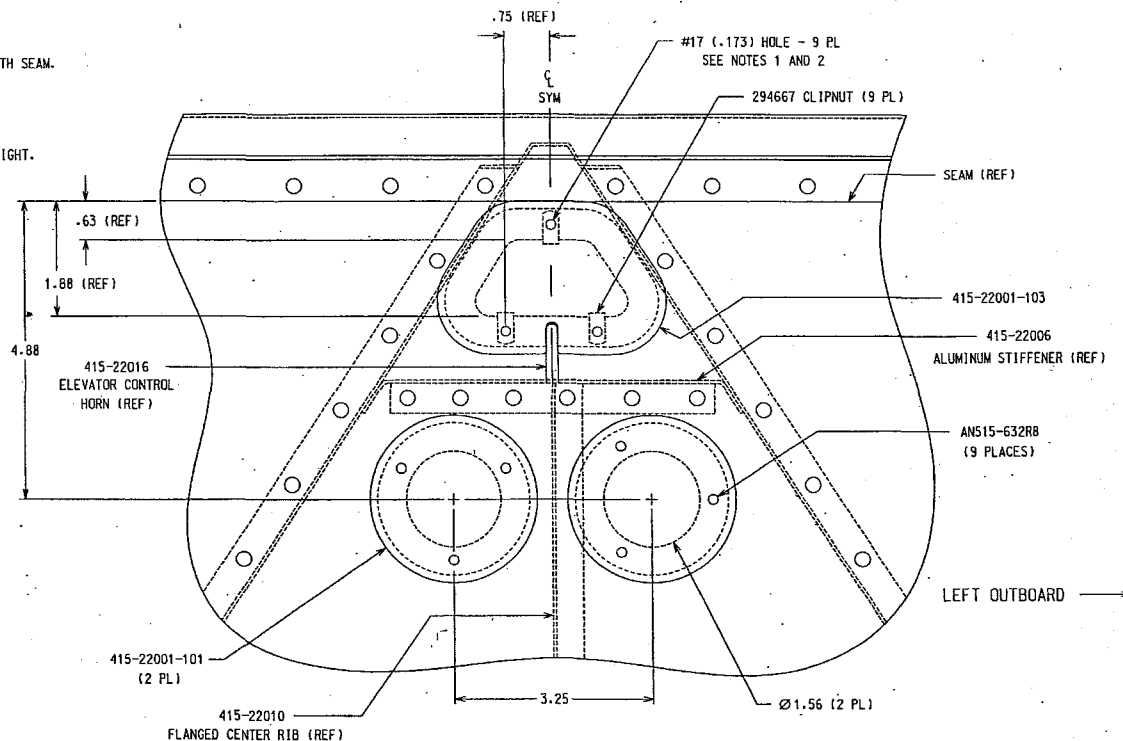

PART NUMBER	NAME	STOCK SIZE	QTY	MATERIAL	SPECIFICATION
294667	CLIPNUT		9		
ANS15-632RB	SCREW		9		
415-22001-105	TEMPLATE		1		
415-22001-103	FORWARD PLATE		1		
415-22001-101	ROUND PLATE		2		
DRAWN BY: N. WOTOVITCH		DATE: 12.20.12	SCALE: NONE	A/C MAKE: ERCOUPE	
LIMITS: ±.06 ±.030 ±1°			UNIVAIR AIRCRAFT CORPORATION 2500 HIMALAYA ROAD AURORA, COLORADO, 80011		
FINISH: NONE					
PAINT: NONE					
TITLES: ELEVATOR - INSPECTION HOLE LOCATION		SHEET NO.: 1 OF 1		DRAWING NO.: 415-22013 INSP	
E.O. NO.	REVISION	DATE	MODELS: 415-C, 415-CD, 415-D		

SK-82

ELEVATOR CONTROL HORN
INSPECTION PLATE KIT

<u>PART NUMBER</u>	<u>QTY</u>	<u>DESCRIPTION</u>
415-22001-101	2	Round Plate
415-22001-103	1	Forward plate
415-22001-105	1	Template
MS35206-230	9	Screw
294667	9	Clipnut
ERCB-34	1	Service Bulletin 34
415-22013 INSP	1	Drawing