

IMMEDIATE ACTION

**SERVICE**



**BULLETIN**

NUMBER 18

Feb. 16, 1939

Rev. Date: 2-18-46

**SUBJECT:** Replacement Tail Brace Wire Nipples

**MODELS AFFECTED:** J2 Cubs, Serial Nos. 1500 to 1999 and  
J3 Cubs, Serial Nos. 2000 to 2609

A considerable number of fatigue failures of the tail brace wires at the threaded section have been reported to this office. These failures have in most instances been caused either by ground handling or vibration.

In order to afford a greater margin of safety in the operation of our Cubs, we have designed a new type of tail brace wire nipple which we are recommending that you install at once, in order to avoid a similar failure in your installation.

This new nipple is long enough to completely cover the threaded section of the wire and has a lock nut on one end which clamps the body of the nipple to the solid section of the wire.

We would also like to call to your attention that by the installation of the new nipple the CAA will no longer require that the tail brace wire be replaced every 250 hours of service.

Note: This new type nipple can be installed on your present type wire.

**PIPER AIRCRAFT CORPORATION, LOCK HAVEN, PA., U. S. A.**

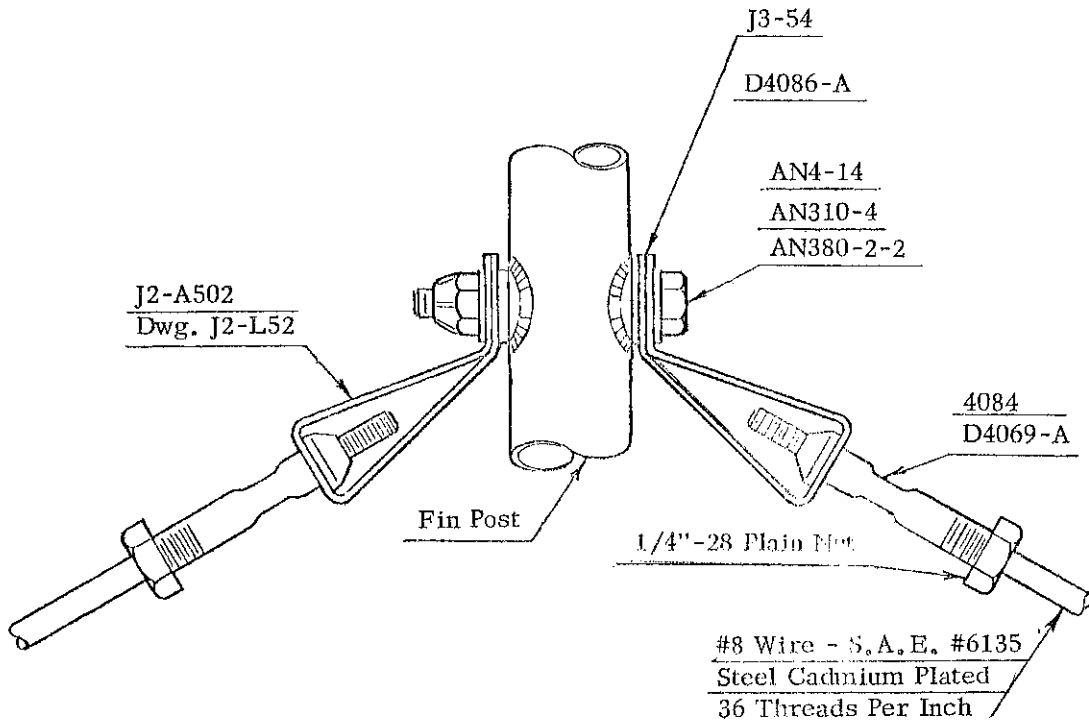

FIN TIE ATTACHMENT

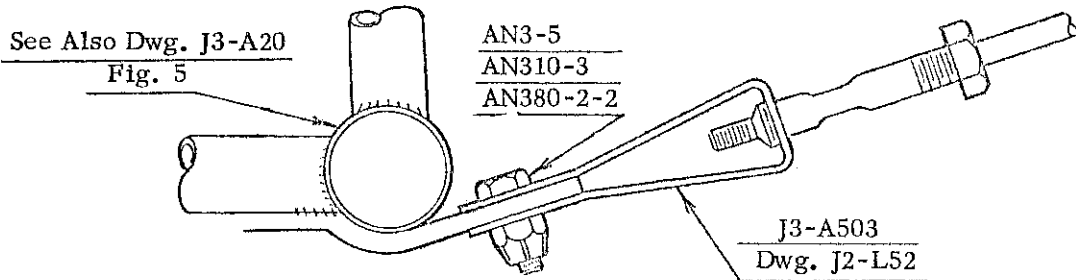

FUSELAGE TIE ROD ATTACHMENT