

SERVICE

LETTER

Service Letter No. 400

March 20, 1963

TO: Distributors, Dealers, Certified Service Centers and Owners

SUBJECT: Tail Brace Rods

MODELS AFFECTED: All PA-12, PA-14 and PA-20 Aircraft and
PA-22 Tri-Pacer Aircraft Serial Nos. 22-1 to 22-7999 incl.

We wish to announce that the round upper and lower tail brace tie rod assemblies, part numbers 10555-02 and 10556-02, respectively, have been approved to replace the upper and lower streamline tail brace tie rod assemblies, part numbers 10074-02 and 10074-03, on PA-12, PA-14, PA-20 and PA-22 aircraft, serial numbers listed above.

The installation of the round tail brace tie rods will eliminate compliance with Piper Service Bulletin No. 183 and F.A.A. AD-60-1-7. Therefore, it is recommended that as the streamline tie rods are retired from service, the round tie rods be installed as a replacement. See Sketch on reverse side for complete details.

(over)

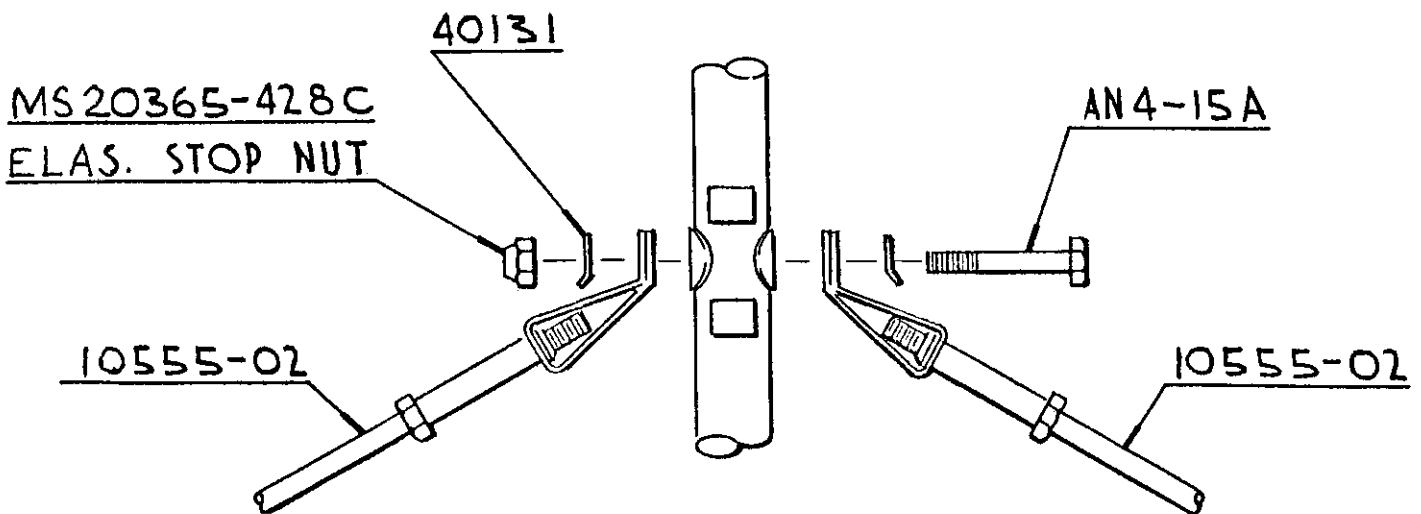
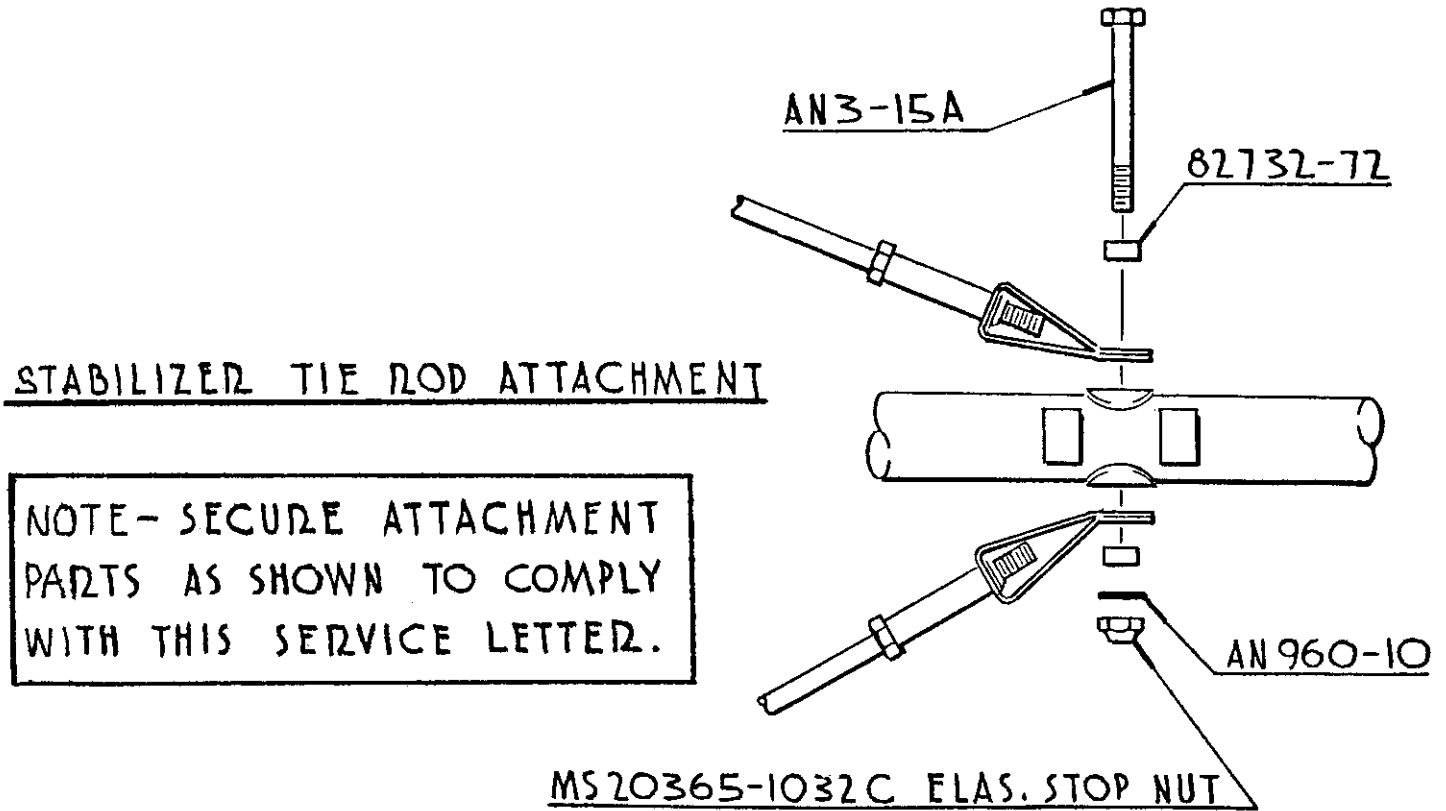
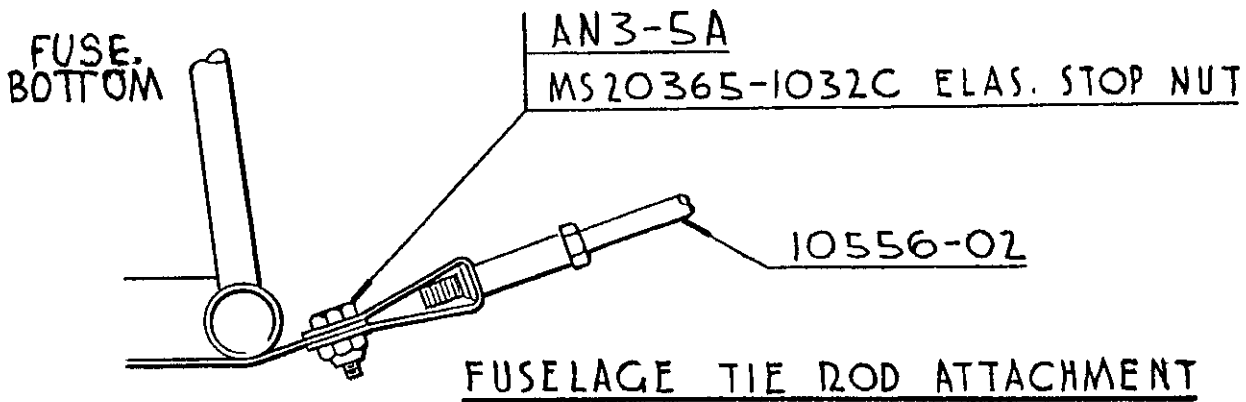

FIN TIE ROD ATTACHMENT