

IMMEDIATE ACTION

# SERVICE

NUMBER 110



# BULLETIN

November 29, 1948

SUBJECT: WINDSHIELD ATTACHMENT

MODELS AFFECTED: PIPER AIRPLANES MODELS PA-15 SERIAL NUMBERS 15-1 TO 15-387 INCL., AND PA-17 SERIAL NUMBERS 17-1 TO 17-214 INCL.

In order to eliminate the possibility of the windshield coming out of its top retaining channel (channel located on tube between front wing hinge fittings) it is strongly recommended that the windshield attachment be reworked to incorporate the use of four machine screws installed in accordance with the sketch below.

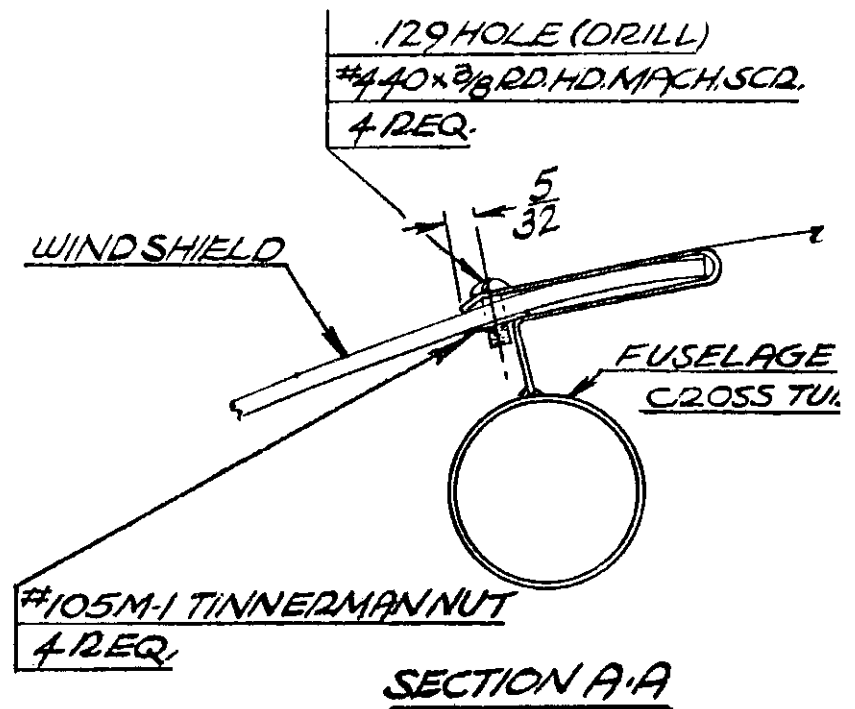
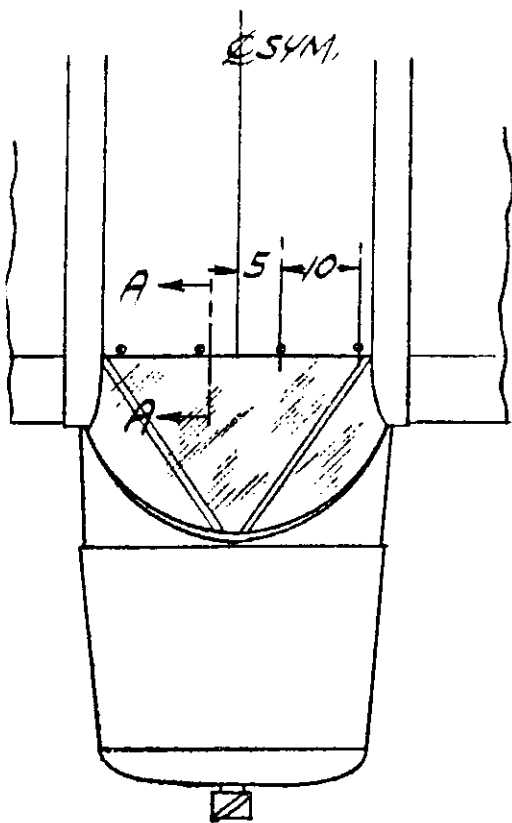

NOTE

DO NOT FORCE DRILL THRU PLEXIGLAS

An appropriate entry should be made in the aircraft log book when the recommended change has been made.

PIPER AIRCRAFT CORPORATION, LOCK HAVEN, PA., U. S. A.