



Piper Aircraft Corporation  
2926 Piper Drive  
Vero Beach, Florida, U.S.A. 32960

# SERVICE *No.* 966 BULLETIN

**PIPER CONSIDERS  
COMPLIANCE MANDATORY**

January 21, 1994

This Service Bulletin is divided into TWO (2) PARTS. Check each PART for subject and serial numbers affected.

## PART I

**SUBJECT:** TAIL SURFACES REPLACEMENT

**MODELS AFFECTED:**

PA-18-150 Super Cub

**SERIAL NUMBERS AFFECTED:**

1809002, 1809004 through 1809011  
1809013 through 1809032  
1809034 through 1809038  
1809043 through 1809045  
1809047, 1809050 through 1809052

**COMPLIANCE TIME:** Within the next six (6) months or at the next regularly scheduled maintenance event, whichever occurs first.

**PURPOSE:** After the initial production of the re-introduced Super Cub, it was discovered that some field aircraft showed evidence of premature internal corrosion in the steel tube structure of the vertical fin and the five tail surfaces (stabilizers, elevators, and rudder).

Analysis of the corroded areas indicates that over time the integrity of the structure will be compromised and any rework of the internal steel tubes on the control surfaces would be impractical or uneconomical.

Therefore, PART I of this Service Bulletin requires the replacement of the tail surfaces with new ones which incorporate improved internal treatment processes during manufacture.

PART II of this Service Bulletin requires the sealing of the leading edge and tail post tubes of the vertical fin.

**APPROVAL:** The technical contents of this Service Bulletin have been approved by the F.A.A.

(OVER)  
ATA: 5500

**INSTRUCTIONS:**

1. Gain access to the rudder and elevator cable turnbuckles and release tension on these cables.
2. Disconnect navigation/anti-collision light wiring at the knife splices located at the lower leading edge of the rudder. (if installed)
3. Remove the necessary hardware, springs and stabilizer tailbrace wires and remove control surfaces from the aircraft.

**NOTE:**

Prior to continuing with the Instructions in this PART, compliance with PART II would be advisable.

4. The new tail surfaces come complete with filler and prime finish. (Aerotec Inc. process)
5. Apply desired finish following the procedures specified by the finish supplier and/or refer to the latest revision of AC43.13 for details on fabric aircraft finishing.

**NOTE:**

Approved finishes are catalyzed polyurethanes. Enamel finishes are not recommended.

6. Inspect condition of forward and aft stabilizer liner tubes. If these tubes are difficult to remove during disassembly or exhibit signs of corrosion or damaged/elongated bolt holes, the liner tube(s) must be replaced. The liner tube bore within the fuselage may require cleaning also.
7. Install new tail surfaces. Use the attached illustrations as follows:
 

- Stabilizer Installation	Sketch 1 and 2
- Stabilizer Installation and Rigging	Sketch 3
- Elevator Installation	Sketch 4
- Bungee Installation	Sketch 5
- Rudder Installation	Sketch 6
- Tailwheel Steering Installation	Sketch 7
8. Check for proper control surface continuity and rigging.
9. Connect navigation/anti-collision light wiring and operationally check (if installed).
10. Make appropriate logbook entry of compliance with PART I of this Service Bulletin.

**MATERIAL REQUIRED:**

<u>One each per aircraft:</u>	<u>Piper P/N</u>
Rudder Assembly	14773-008
Stabilizer L.	12790-806
Stabilizer R	12790-807
Elevator R.	12789-807
Elevator L.	12789-806
Tube - Rear Liner	86062-079
Tube - Liner	86062-080

**AVAILABILITY OF PARTS:** Your Piper Field Service Facility

**PART II**

---

**SUBJECT:** Vertical Fin Corrosion Protection

**MODELS AFFECTED:**

PA-18-150 Super Cub

**SERIAL NUMBERS AFFECTED:**

1809001 through 1809011  
1809013 through 1809032  
1809034 through 1809038  
1809043 through 1809045  
1809047,  
1809050 through 1809052  
1809054

**COMPLIANCE TIME:** Within the next six (6) months or at the next regularly scheduled maintenance event, whichever occurs first.

**PURPOSE:** PART II of this Service Bulletin requires the complete sealing of the forward and aft tubes of the vertical fin (leading edge and tail posts).

**INSTRUCTIONS:**

1. On the top aft portion of the vertical fin, cut a hole in the fabric to allow entrance to the aft post of the fin (the aft post is open-ended at this point). Per manufacturer's instructions, thoroughly mix a sufficient amount of Thiokol MC-236 (or equivalent) sealant and fill the aft post completely.

**NOTE:**

Once the sealant begins to exit the bottom of the tail post, place a strip of metal, wood or phenolic to the bottom of the post to allow the sealant to dam-up and fill the post. When the sealant has jelled the strip should be removed to complete curing of the sealant.

2. After the sealant has cured, cover the hole created above the aft post using the "dollar patch" technique. Please note that cure times may vary with ambient temperatures and weather conditions.
3. Remove the navigation antenna, if installed, at the upper forward end of the vertical fin to access the leading edge tube top.

**NOTE:**

For those aircraft not equipped with a navigation antenna, install antenna doublers, Piper Part Number 14313-00 on each side of the upper forward vertical fin. Once the adhesive is allowed to cure, cut out the inside periphery of the doublers to access the leading edge tube top.

**INSTRUCTIONS (CONT'D.):**

3. (CONT'D) Per manufacturer's instructions, thoroughly mix a sufficient amount of Thiokol MC-236 (or equivalent) sealant and fill the forward/leading edge tube completely.

**NOTE:**

When filling the forward/leading edge tube, ensure that sealant does not enter the stabilizer jackscrew mechanism at the base of the tube.

4. Re-install the navigation antenna and operationally check navigation equipment. For aircraft not equipped with a navigation antenna, fabricate and install cover plates after the sealing operation. Cover plate size should be consistent with those of the doublers.
5. Paint dollar patch and the fabricated cover plates (if no navigation antenna installed) to match the color of the aircraft.
6. Make logbook entry of compliance with PART II of this Service Bulletin.

**MATERIAL REQUIRED:** One (1) each dollar patch, two (2) each cover plates, Thiokol MC-236 Sealant, Piper P/N 279-060 (1 gal. container) as required.

Material, hardware or sealants may be obtained/fabricated locally or through your local Piper Field Service Facility. Refer to the attached sketches or the Parts Catalog for appropriate part numbers.

**AVAILABILITY OF PARTS:** Local procurement/fabrication, or your Piper Field Service Facility.

---

**EFFECTIVITY DATE:** This Service Bulletin is effective upon receipt.

**SUMMARY:** There is no factory participation applicable to this Service Bulletin. However, special pricing does apply for the Material Required in PART I. The suggested list price for the five tail surfaces of is \$8,369.36 plus \$238.00 crating. For 180 days from the effective date of this release, Piper will offer these five surfaces for a total of \$6,695.50. In addition Piper will allow \$3,000.00 credit for the old flight control surfaces when replaced and returned to Piper in the original crates of the new flight control surfaces. This offer will not be extended beyond 180 days.

Please contact your Piper Field Service Facility to arrange for compliance with this Service Bulletin in accordance with the Compliance Time indicated.

**NOTE:** If you are no longer in possession of this aircraft, please forward this information to the present Owner/Operator and notify the factory of address/ownership corrections. Changes should include model, serial number, current owner's name and address.

Corrections/Changes should be directed to:

Piper Aircraft Corporation  
Attn: Customer Services  
2926 Piper Drive  
Vero Beach, FL 32960

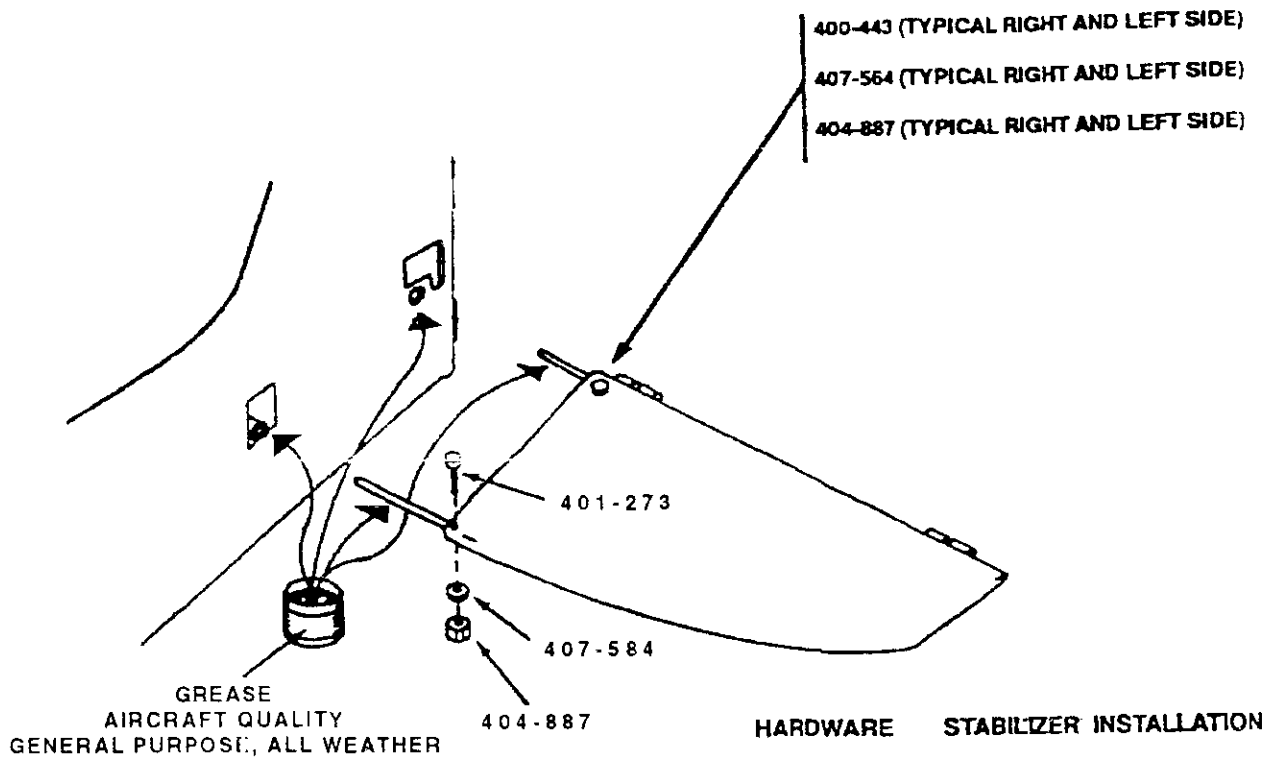

HARDWARE		STABILIZER INSTALLATION	
<u>Part No.</u>	<u>Nomenclature</u>	<u>Quantity</u>	
400-443	Bolt-AN3-12A	4	
407-564	Washer-AN960-10	4	
404-887	Nut-MS20365-1032C	4	

A. Identify the LEFT stabilizer and lay it on a suitable work surface. Apply a thin coat of all weather grease to the inside ends of the front and rear stabilizer tubes, then install the front and rear liner tubes in their proper locations and secure with the same hardware as removed.

B. Apply a thin coat of grease to the exposed ends of the liner tubes then install the stabilizer onto the aircraft until the stabilizer is tight against the mounting brackets.

C. Apply grease to the inside of the front and rear tubes of the RIGHT stabilizer and install it onto the ends of the liner tubes that protrude from the side of the fuselage. It may be necessary to have a second person hold the left stabilizer as a back up.

D. Make sure the drain grommets on the trailing edges of both stabilizers are on the bottom of both surfaces.

**SKETCH 1 - STABILIZER INSTALLATION**

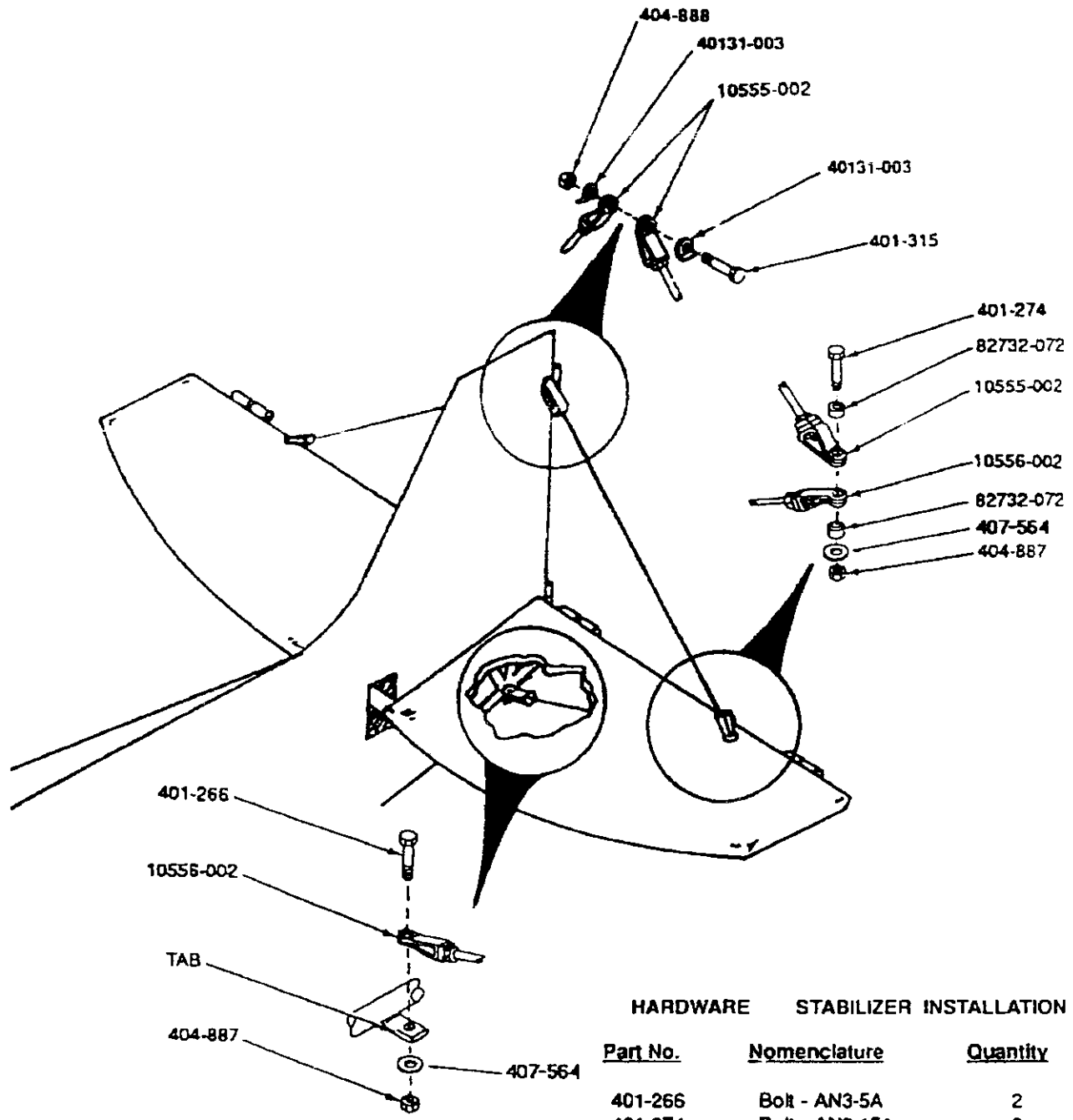

**HARDWARE STABILIZER INSTALLATION**

<u>Part No.</u>	<u>Nomenclature</u>	<u>Quantity</u>
401-266	Bolt - AN3-5A	2
401-274	Bolt - AN3-15A	2
401-315	Bolt - AN4-15A	1
404-887	Nut - MS20365-1032C	4
404-888	Nut - MS20365-428C	2
407-564	Washer - AN960-10	4
40131-003	Radius Washer	2
82732-072	Bushing	4

**SKETCH 2 - STABILIZER INSTALLATION**

- A. Place the tail of the aircraft on a sawhorse so the stabilizers are at a comfortable height, then place a level across the rear seat cross tube and level the fuselage laterally by deflating a tire.
- B. Place a 30 inch level on top of the LEFT stabilizer trailing edge tube and adjust the lower brace wire end fittings evenly while lifting up on the stabilizer until the surface is level.
- C. Level the RIGHT stabilizer in the same manner as the left, making sure that equal threads are exposed at each end of the lower wires.
- D. Tighten both upper wires evenly and recheck the levelness of the horizontal stabilizers but do not bother with the vertical fin at this time.
- E. When the stabilizers are level tighten all wires evenly until a deflection of 1/2 inch yields 10 pounds when the middle of one of the upper and lower wires is pulled in a 90 degree direction with a fish scale.
- F. Adjust the vertical fin to a perpendicular position by placing the level vertically along side of the fin trailing edge tube and move the upper portion of the fin to the left or right by loosening one of the upper wires and tightening the other wire equally to maintain the wire tension but yet move the fin to a perfectly vertical position.
- G. Make sure all (8) jam nuts on the wire end fittings are tightened snugly.

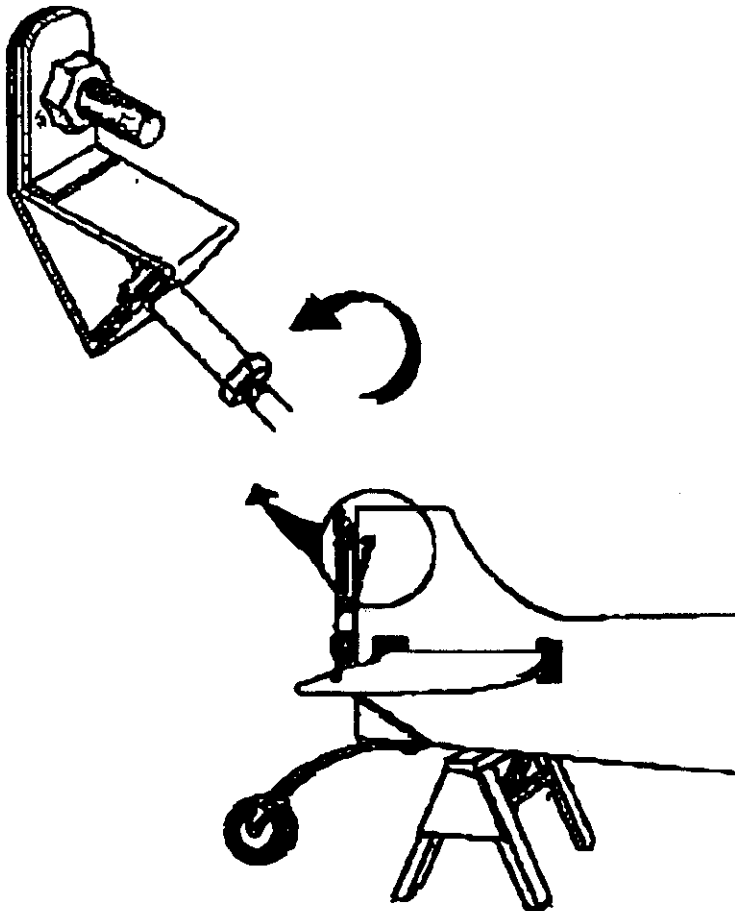

SKETCH 3 - STABILIZER INSTALLATION AND RIGGING

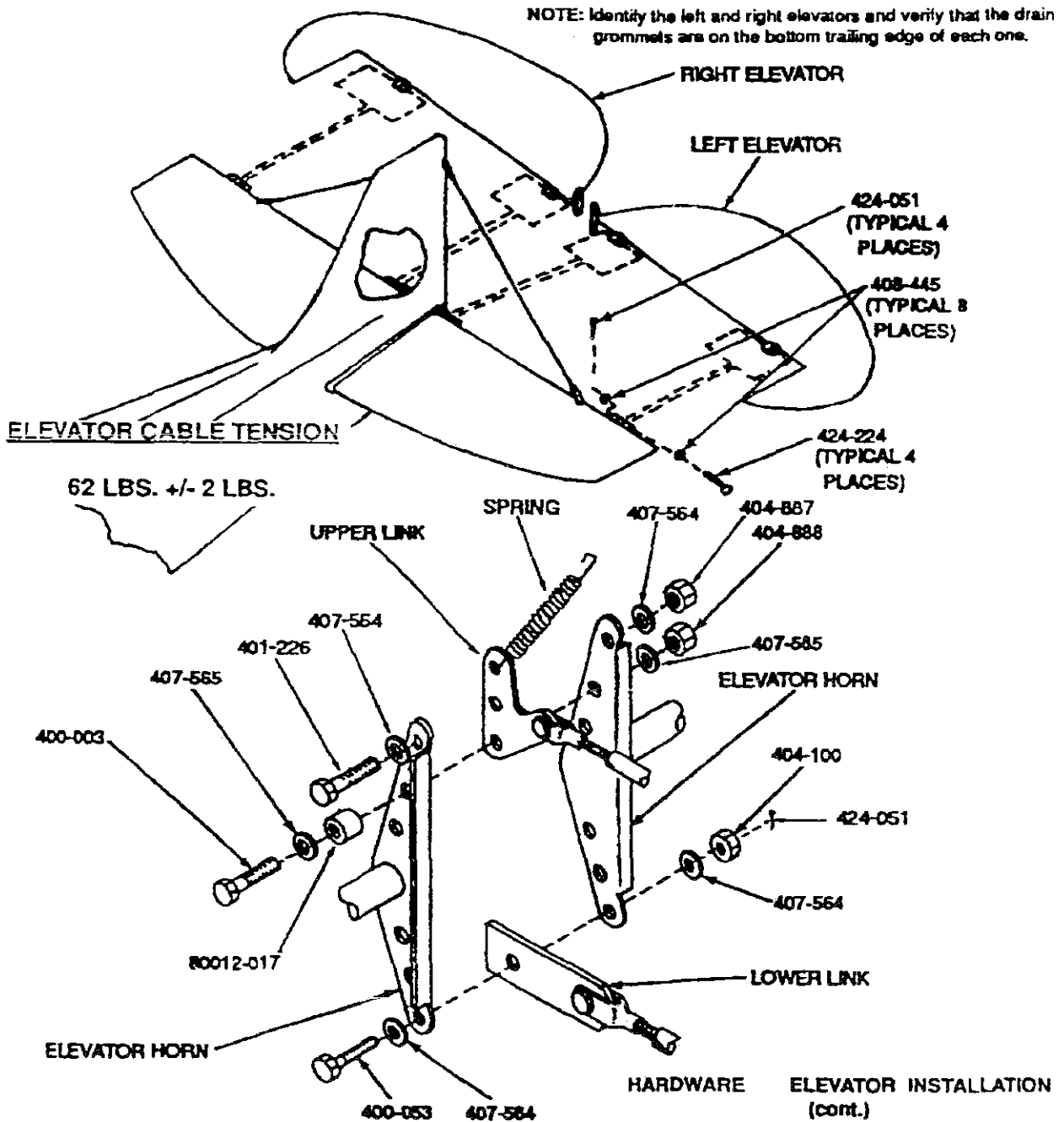

HARDWARE: ELEVATOR INSTALLATION

HARDWARE ELEVATOR INSTALLATION (cont.)

<u>Part No.</u>	<u>Nomenclature</u>	<u>Quantity</u>	<u>Part No.</u>	<u>Nomenclature</u>	<u>Quantity</u>
			407-565	Washer- AN960-416	2
			407-564	Washer - AN960-10	4
424-224	Pin -AN394-55 stl. flt. head.	4	408-445	Washer- P/N 80122-86	8
400-003	Bolt - AN4-6A	1	404-888	Nut - MS20365-428C	1
400-053	Bolt - AN3-6	1	404-100	Nut - AN310-3	1
401-266	Bolt - AN3-5A6	1	404-887	Nut - MS20365-1032C	1
			424-051	Cotter Pin - AN380-2-2	4

SKETCH 4- ELEVATOR INSTALLATION



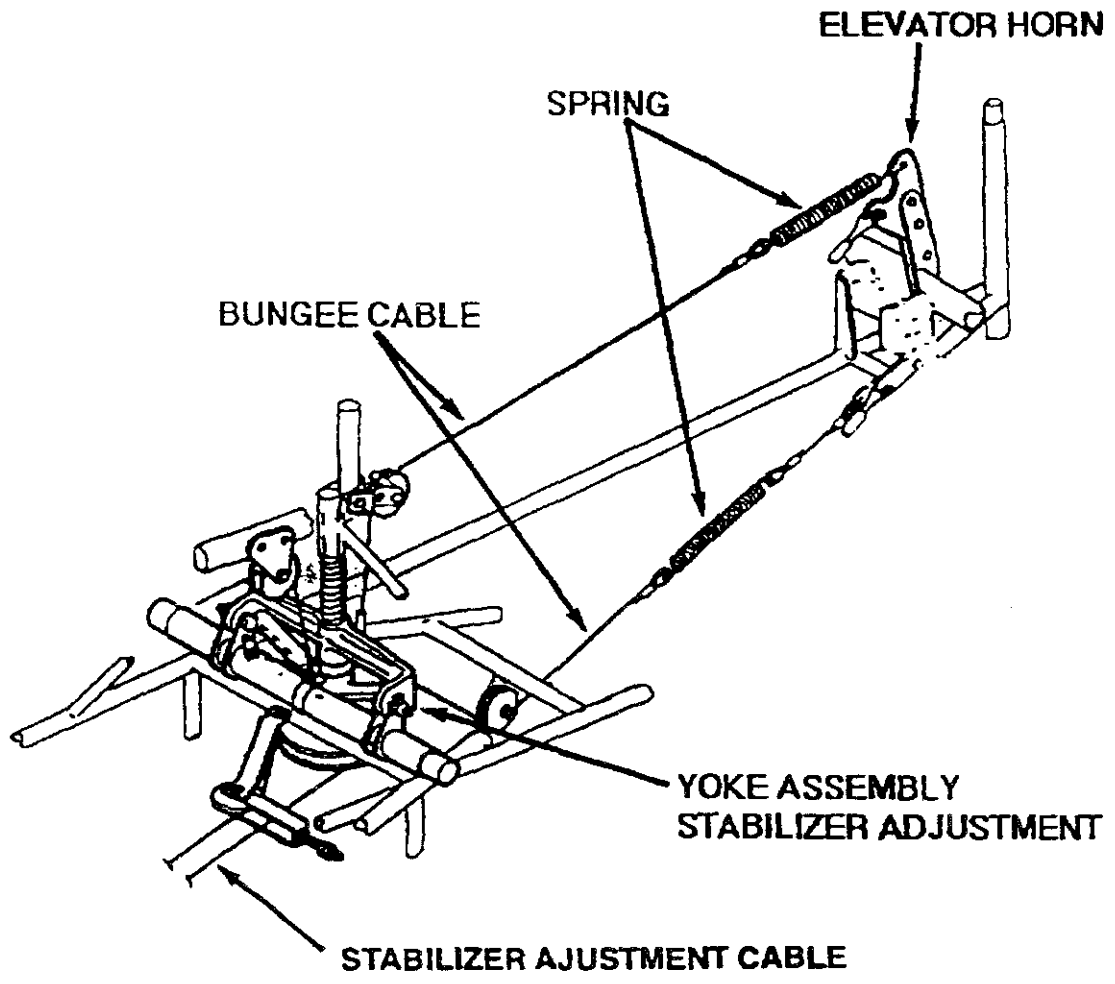

SKETCH 5 - BUNGEE INSTALLATION

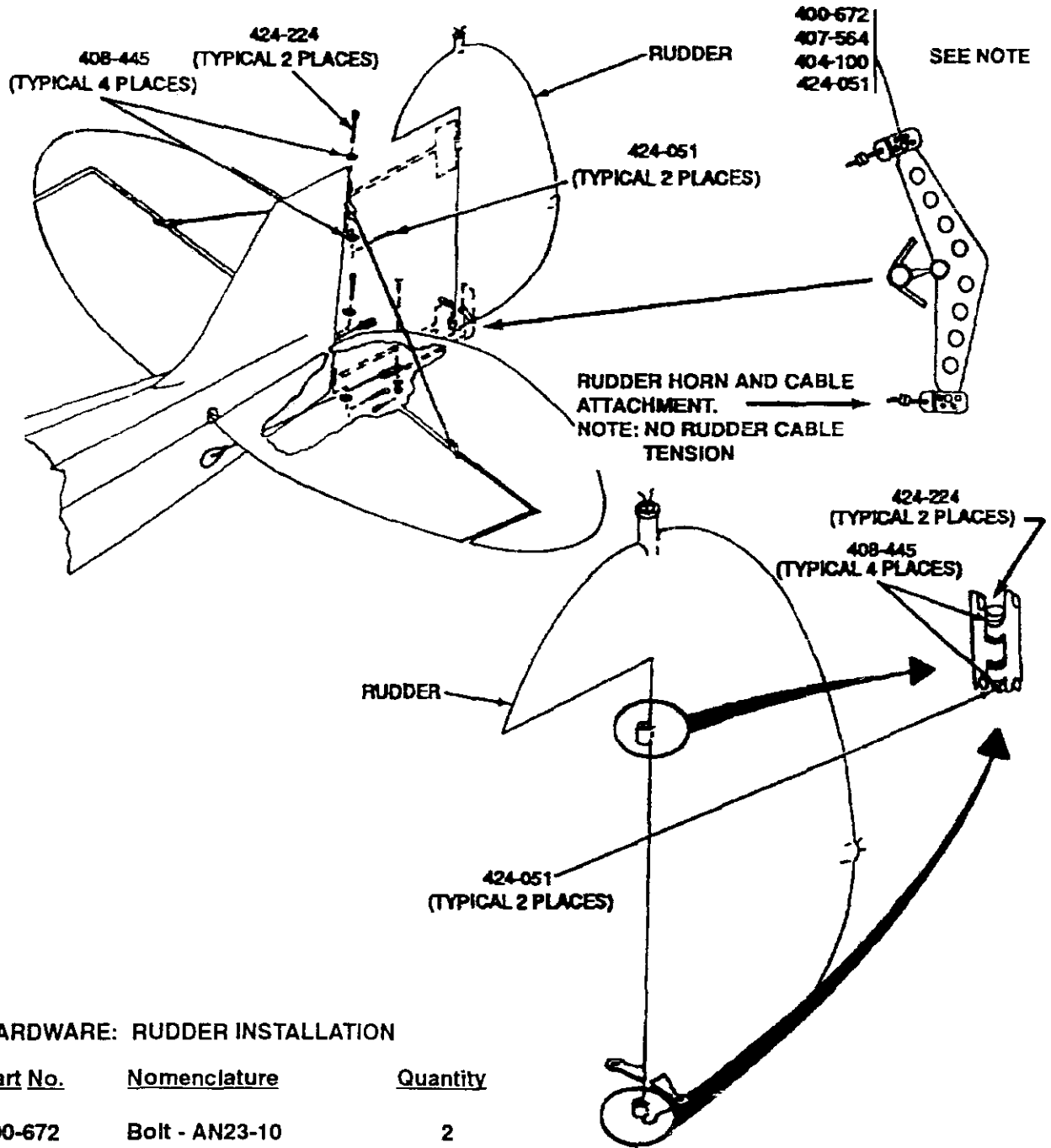

**HARDWARE: RUDDER INSTALLATION**

<u>Part No.</u>	<u>Nomenclature</u>	<u>Quantity</u>
400-672	Bolt - AN23-10	2
407-564	Washer - AN960-10	2
404-100	Nut - AN310-3	2
424-051	Cotter Pin - AN380-2-2	2
424-224	Pin - AN394-55 stl. ft. head	2
408-445	Washer- AN960-	4
424-051	Cotter Pin - AN380-2-2	4

**SKETCH 6 - RUDDER INSTALLATION**

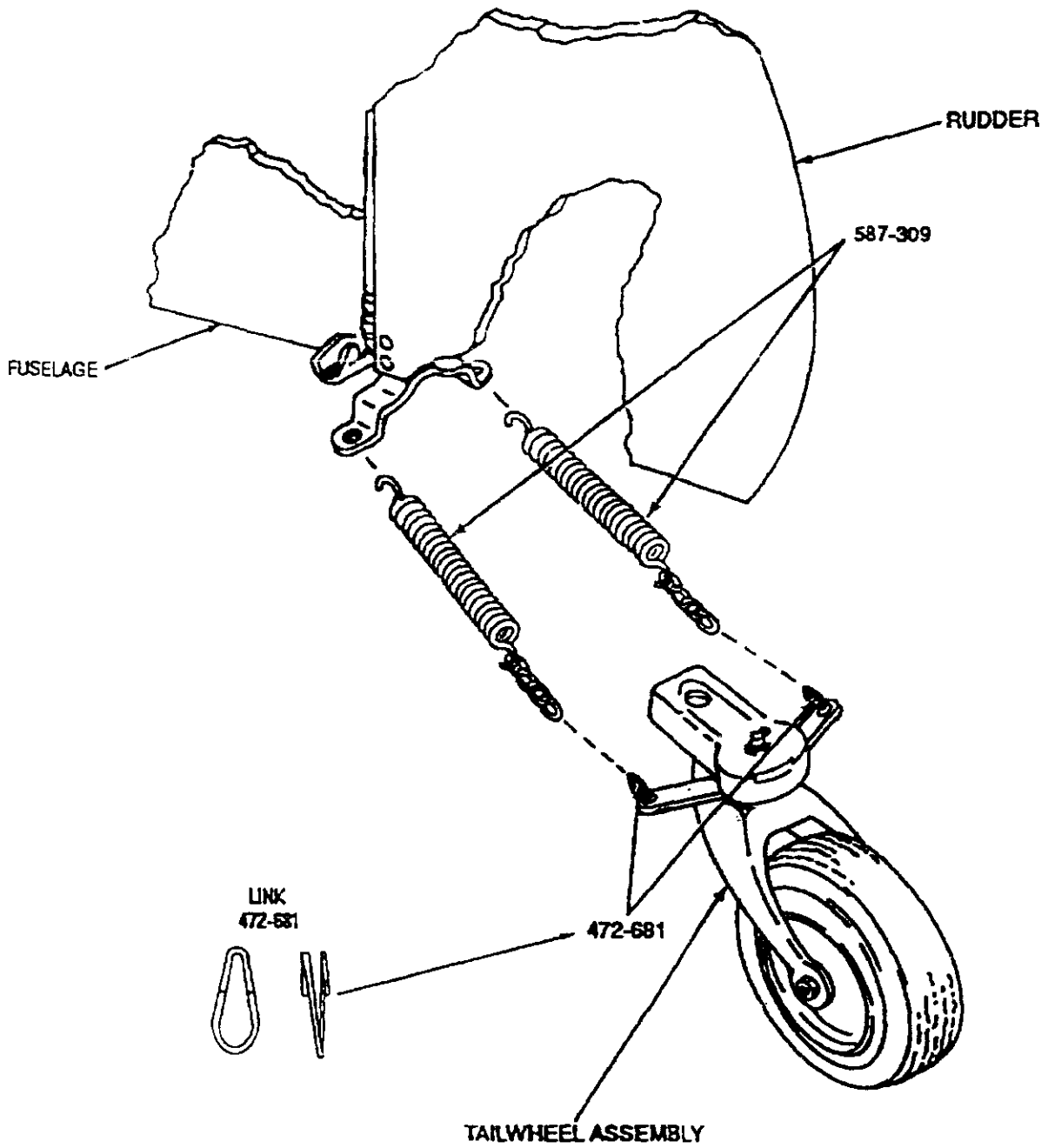

SKETCH 7 - TAILWHEEL STEERING INSTALLATION