



# SERVICE LETTER

No. 138

Piper Aircraft Corporation

Lock Haven, Pennsylvania, U.S.A.

March 9, 1950

TO: All Owners of PA-20 Airplanes up to Serial No. 20-115

SUBJECT: Rudder Pedal Tube Attachment

It is recommended that a #6 x 3/8" Parker Screw be installed in the rudder pedal tube clamp of the right hand rudder pedals to eliminate the possible rotation of the rudder pedal cross tube on the torque tube arm. The Parker screw should be installed, as per sketch shown below.

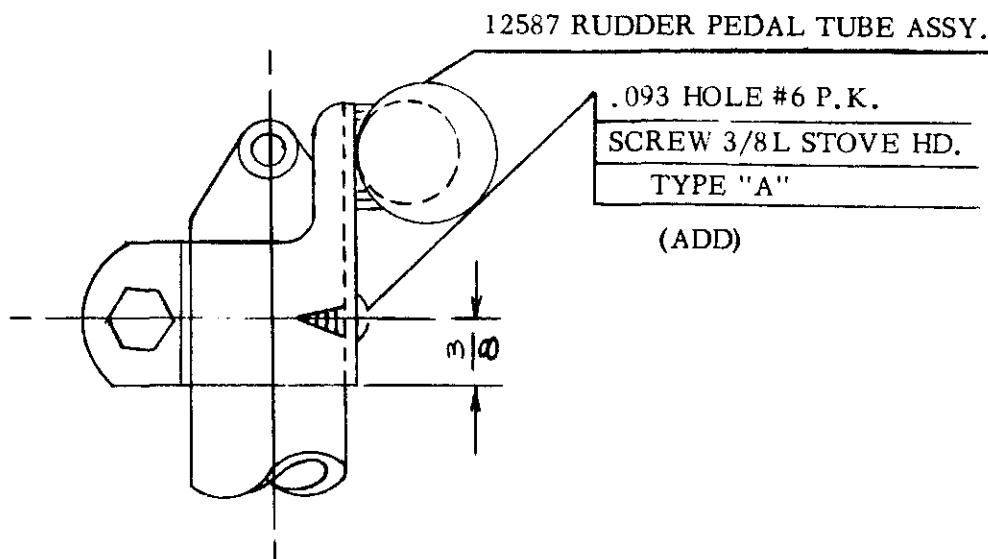

PIPER AIRCRAFT CORPORATION

Rolland Boardman  
Service Manager

RB:df/lh