

# SERVICE



# LETTER

Service Letter No. 212

October 7, 1953

To: All Distributors, Dealers and Owners

Subject: Nose Wheel Shimmy Dampener, Part No. 13086-00

Models Affected: All 1953 Model PA-22's with serial numbers 22-807 to 22-1614 inclusive, 22-1616 to 22-1631 inclusive, 22-1633 to 22-1635 inclusive, 22-1638, 22-1642, 22-1646 to 22-1648 inclusive, 22-1651, 22-1653, 22-1655, 22-1656, 22-1658 to 22-1661 inclusive, 22-1666, 23-1667, 22-1672, 22-1678, 22-1680, 22-1682 and 22-1683.

During the past few months we have received from the field a number of shimmy dampeners, part number 13086-00, on which a separation has occurred between the assembly body and the end plate. This separation was due to solder breaking loose and the internal fluid pressure plus the friction of the plunger forcing the end plate outward.

There is a possibility that a binding action will result and it is therefore recommended that regular inspections be conducted at this point to be on guard against possible failure.

All production airplanes have been modified in accordance with the sketch shown on the reverse side of this Letter and it is felt that this modification can be satisfactorily executed in the field as a service-fix. Upon inspection if the shimmy dampener shows signs of separation, it will be exchanged free-of-charge at the nearest Piper Distributor or Dealer.

We would like to further recommend that the shimmy dampener be modified at the earliest convenience. The expense of this modification must be borne by the owner.

Very truly yours,

PIPER AIRCRAFT CORPORATION

  
Rolland Boardman  
Service Manager

RB:lh

PIPER AIRCRAFT CORPORATION, LOCK HAVEN, PA., U. S. A.

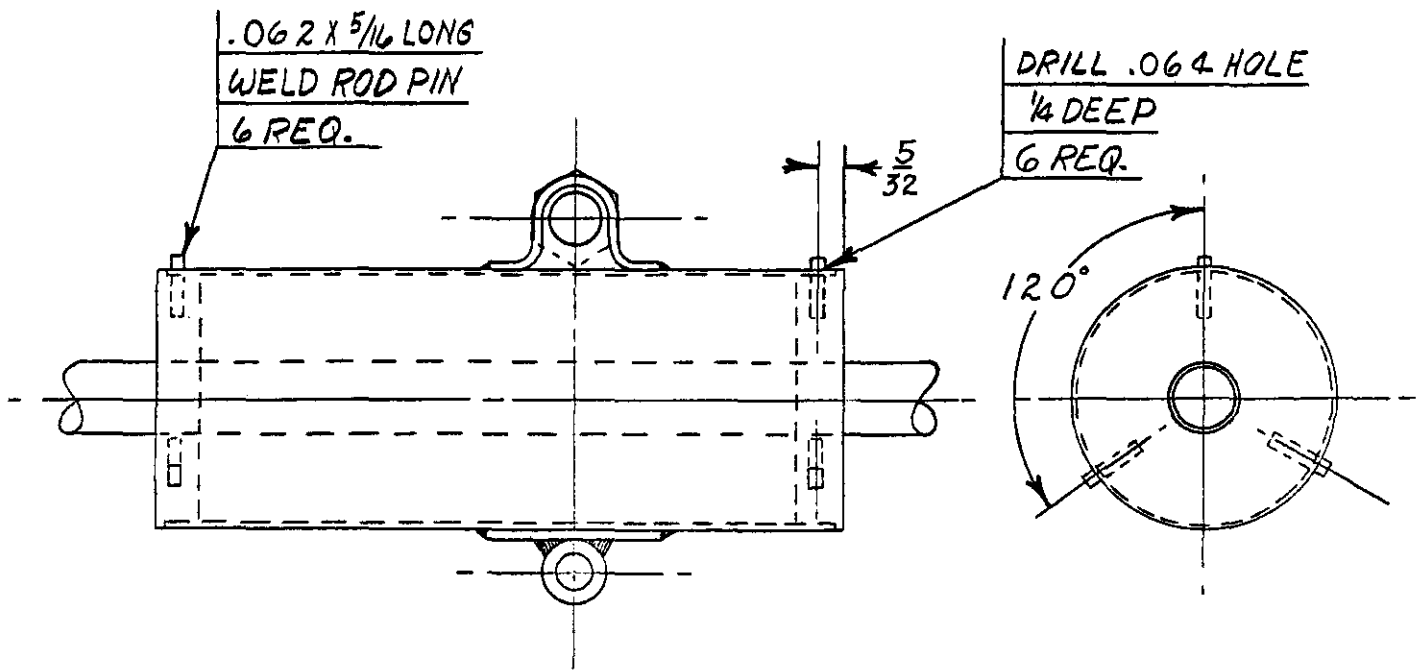

NOTE:

DRIVE PIN INTO EACH HOLE AND SOLDER END, COVERING  
PIN WITH SOLDER.