

SERVICE

BULLETIN

STINSON DIVISION

TITLE: Tail Wheel Installation

BULLETIN NO. 252

MODELS AFFECTED: 108 (Voyager and Flying Station Wagon)

Date: June 26, 1947

Gentlemen:

We recently received several reports on the subject of non-functioning steerable tail wheels. A complete investigation of this subject indicated that the tail wheel steering arms were of proper specifications and that the difficulty, where encountered, was caused by the tail wheel arm striking the end of the tail wheel installation bolt. When the tail wheel steering arm swings forward it strikes the end of the bolt and jams the tail wheel mechanism before it reaches the release point.

If any Voyagers in your territory are reported to be experiencing this type of difficulty, we recommend that the tail wheel assembly bolt be removed and two washers installed under the head of the bolt as indicated in the sketch below.

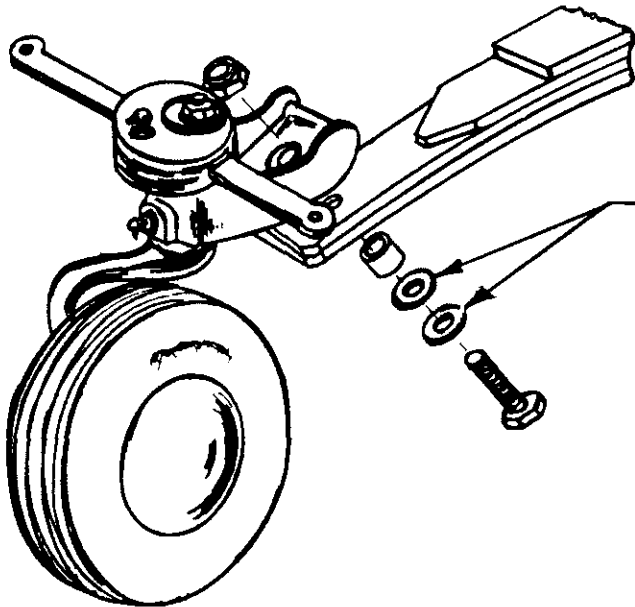

Yours very truly,

Rolland Boardman
Service Manager