

Subject

Identifying UNDERHOOD™140cfm and 150cfm Clutch for Replacement

System or Parts affected

UNDERHOOD™ 140cfm and 150cfm – Compressor Serial Number starts with P140xxxxxxxx.

Overview

- As of June 2016, the original design clutch for UNDERHOOD™140 / 150 (VMAC P/N: P200039) is no longer available.
- P/N: P200039 has been superseded by the new P/N: P200050.
- P/N: P200050 is not backwards compatible to the original (old style) compressor front gear case.
- A700234 FRONT GEAR CASE RETROFIT KIT is available to retrofit compressors from the old-style clutch to the new clutch if a replacement clutch is required.
- Once the A700234 kit has been installed, in the event of a future clutch failure, the new style P200050 clutch will be all that is required.

Identifying the clutch and choosing replacement parts

Obsolete clutch with 4 bolt stator mount (P/N: P200039):

- The P200039 is identifiable by the 4 bolts holding the clutch stator/field coil to mounting points on the front gear case cover of the compressor. See *Figure 1*.

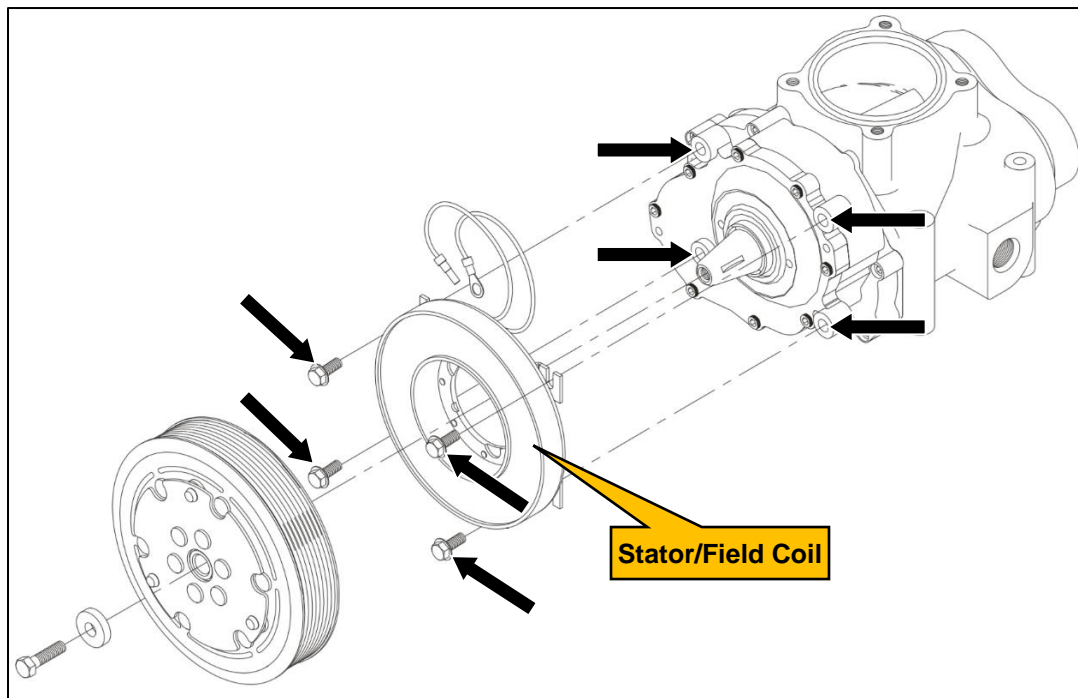

Figure 1

If a replacement clutch is required for a UNDERHOOD™140 / 150 with the old-style clutch, order kit number A700234, which contains the new-style P200050 clutch and an updated front gear case cover assembly.

Document	Version	Department	Revision Details	Revised by	Tech	Engineering	Implemented
EXT-UH-010	A	Tech	Document Release	BDJ	MSP	N/A	15 Nov 2021

Subject

Identifying UNDERHOOD™140cfm and 150cfm Clutch for Replacement

New-Style P200050 clutch with 3 bolt stator mount:

- The new design P200050 clutch is fastened to the compressor gear case using 3 bolts inside the clutch stator. These bolts are not visible when the clutch is assembled. See Figure 2.

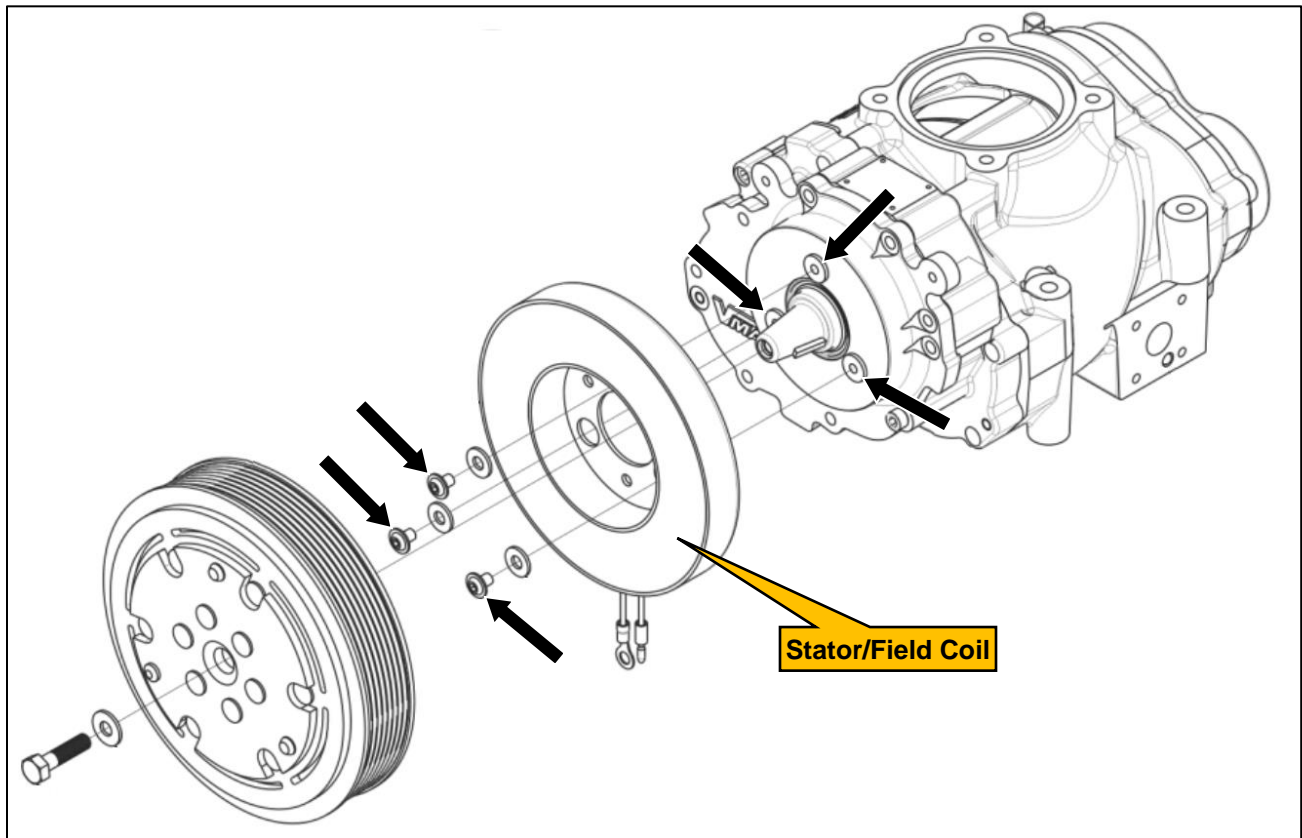

Figure 2

Document	Version	Department	Revision Details	Revised by	Tech	Engineering	Implemented
EXT-UH-010	A	Tech	Document Release	BDJ	MSP	N/A	15 Nov 2021