

ANSSI Support

The French network and information security agency, Agence Nationale de la Sécurité des Systèmes d'Information (ANSSI), stipulates that the communication between the card and the access controller is fully encrypted and secured. To achieve this, all security features should reside in a secured area of the facility. Therefore, transparent (passive) readers are required to ensure the security keys are not exposed at the door. A transparent reader is a door reader that only understands how to exchange smart card commands and responses with an application located inside the secured area. The transparent reader does not interpret the data on the card.

System Overview

In an effort to support the stipulations set forth by ANSSI, OnGuard 7.5 Update 1 provides an integrated ANSSI solution using OSDP readers connected to LNL-X4420 access panels enabled for embedded ANSSI authentication.

Licensing

Two licenses are required:

- SWG-1560 - License to turn on the ANSSI Transparent Reader Solution
- SWG-ANSSI-004 - License for ANSSI Transparent Reader Capacity

Order one unit, 4 Transparent Readers can be configured per LNL-X4420 controller.

Order 10 units, 40 Transparent Readers can be configured.

Card Technology

HID Global's iCLASS[®] Seos[™] smart cards are required to ensure the level of security on the card, as the data on the card is protected with the multiple layers of encryption.

Communication

Communication between the access controller and readers is via OSDP v2 protocol which is a fully encrypted, bi-directional signal (OSDP Secure Channel). The reader is fully secure as it does not contain any security information and is just transmitting the encrypted signal to the controller.

Hardware Configuration

The ANSSI Transparent Reader Solution is supported on LNL-X4420 on-board or LNL-1320 Series 3 and LNL-1300 Series 3 reader ports.

The LNL-X4420 Intelligent Controller

A maximum of four (4) transparent readers supported per LNL-X4420. Remaining reader capacity (60 readers) is usable as standard readers.

Figure 1. LNL-X4420 Configuration

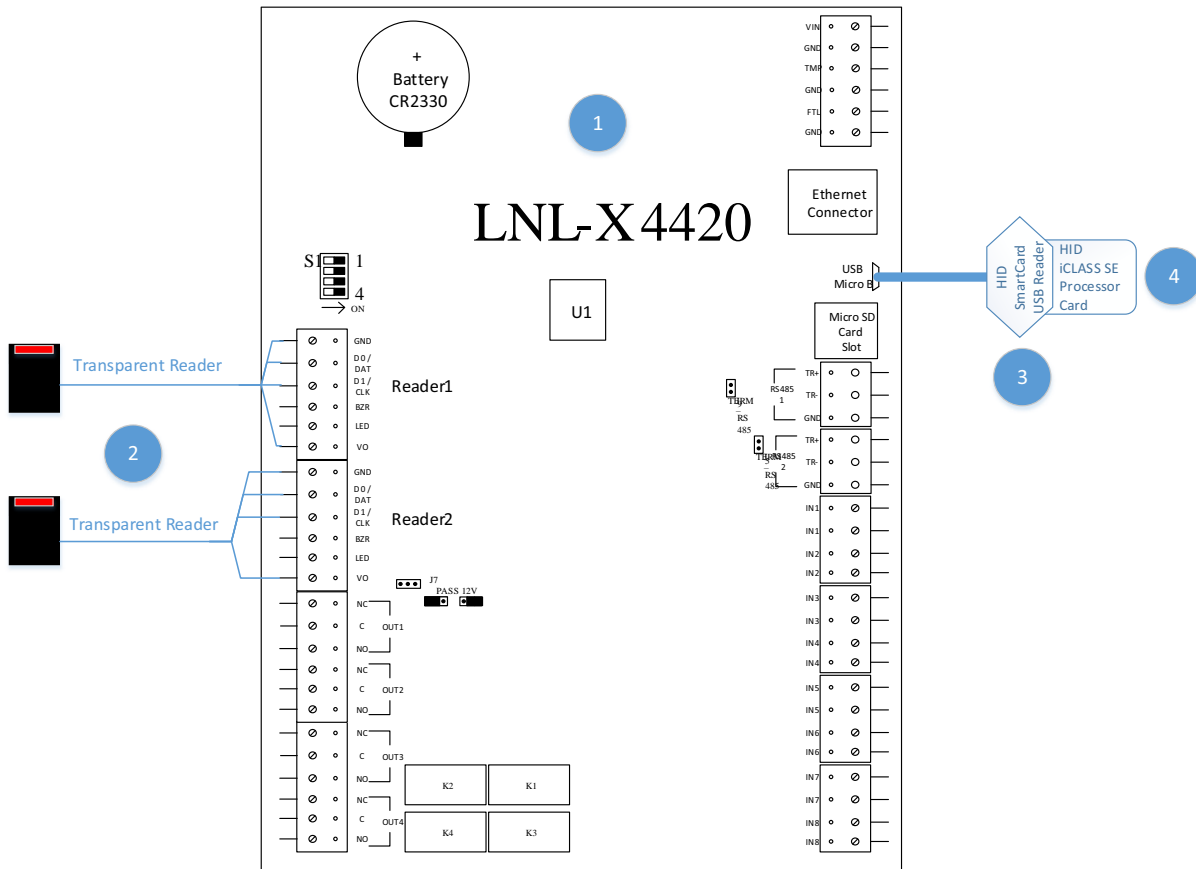

1. LNL-X4420 Access Panel
2. Transparent Readers
 - Configured without keys
 - OSDP smart card
3. HID USB Smart Card Reader
 - Micro B USB connection to LNL-X4420
4. HID iCLASS Processor Card
 - Secure element for key storage

Downstream Devices

Communications to the controller is AES-256 Encrypted (automatically). A maximum of four (4) Transparent Readers supported per LNL-X4420.

Figure 2. SIO Configuration

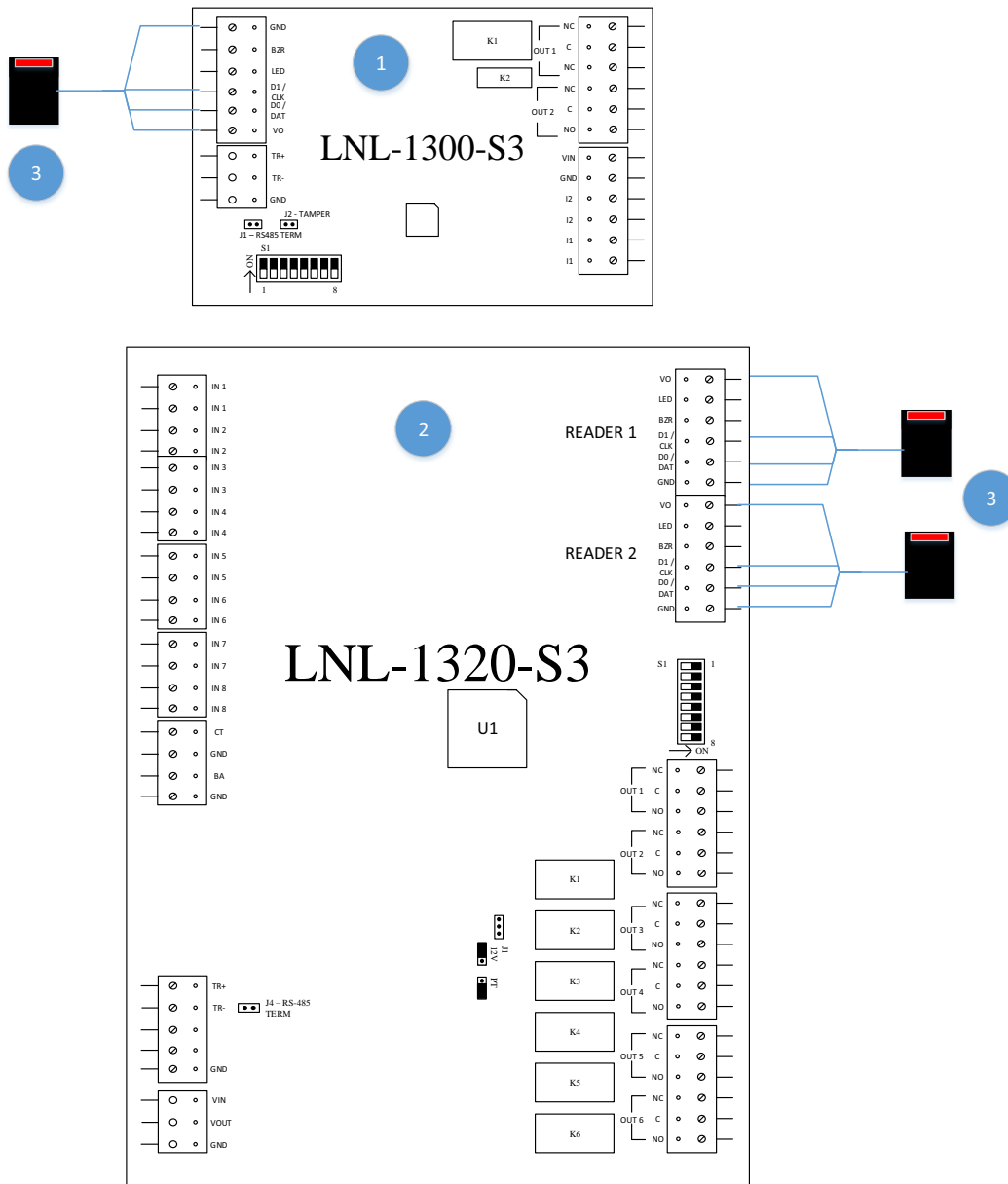

1. LNL-1300-S3 (Single Reader Interface)
2. LNL-1320-S3 (Dual Reader Interface)
3. Transparent Readers:
 - Configured without keys
 - OSDP smart card

OnGuard Configuration

In OnGuard, the ANSSI reader authentication mode is the mechanism used by the authenticated readers to validate the card to meet the stipulations set forth by ANSSI.

ANSSI Transparent Readers are supported on LNL-X4420 on-board or LNL-1320 Series 3 and LNL-1300 Series 3 reader ports if the LNL-X4420 is enabled for this functionality.

Here is an overview of the configuration process:

- In System Administration:
 - Configure the controller to operate using the ANSSI Add-On Module.
 - Configure the readers for ANSSI. A maximum of four (4) Transparent Readers are supported per LNL-X4420 (through a combination of on-board and downstream reader ports on Series 3 reader interfaces).
 - Configure the Reader modes as ANSSI.
- In Alarm Monitoring: Download the ANSSI Add-On Module to the controller.

Configure Transparent Readers for ANSSI

From System Administration, complete the following steps:

1. From the **Access Control** menu, select **Access Panels**. The Access Panels folder opens.
 - a. On the LNL-X4420 form, add or modify the panel.
 - b. On the Options sub-tab, select “ANSSI” from the **Auxiliary module type** drop-down.
 - c. Click [OK].
2. From the **Access Control** menu, select **Readers and Doors**. The Readers and Doors folder opens.
3. On the General form, click [Add].
 - a. In the **Name** field, enter a name for the reader.
 - b. In the **Panel** drop-down, select the LNL-X4420 to which the authenticated reader is connected.
 - c. Select the applicable reader **Type**:
 - “LNL-1300 (Single Interface)” - applicable for LNL-1300 Series 3 only
 - “LNL-1320 (Dual Interface)” - applicable for LNL-1320 Series 3 only
 - “Onboard Reader”
 - d. Select the **Output** “OSDP Protocol”.
 - e. Select the **Authenticated reader** check box. (The **Authenticated reader** check box is re-tasked in the ANSSI solution to be a Transparent Reader).
 - f. Select “ANSSI” as the authentication mode when the reader is **Online (Reader Modes)**. The OSDP Baud rate is automatically changed to a higher baud rate than the default as recommended.
 - g. Select the reader mode the reader will be in when the panel is **Offline (Reader Modes)**.
 - h. Select one or more card formats.
 - i. Click [OK].

From Alarm Monitoring, complete the following steps:

1. Open the System Status view.

2. Right-click on the LNL-X4420 you enabled with the ANSSI solution, and then select ***Auxiliary Module Firmware > Download Firmware***.
For more information, refer to “Access Panel and Alarm Panel Right-click Options” section in the Alarm Monitoring User Guide.