

# VA - Master Schedule (MSC)

November  
2025

## VA - Master Schedule (MSC)

- [Version Control](#)
- [Purpose](#)
  - [Disclaimer](#)
- [Summary, Overview, & Record Linking](#)
  - [Summary:](#)
    - [Product Version](#)
    - [File Name Convention](#)
    - [Reporting Year](#)
    - [Reporting Scope](#)
  - [Record Types](#)
    - [Summary](#)
  - [Record Linking and DOE Validation](#)
    - [Big Picture](#)
    - [B and G Records](#)
    - [C to A](#)
    - [C to D](#)
    - [C to F](#)
    - [D to \(E or B\)](#)
    - [E to D](#)
    - [F to D](#)
    - [Special Notes](#)
  - [Extract Editor Requirements](#)
    - [Additional Logic](#)
  - - [Header Requirements](#)
    - [Special Notes](#)
  - - [Footer Requirements](#)
    - [Special Notes](#)
    - [C/ F Shared Selection Criteria](#)
  - - [Teacher of Record \(B/D/E/F\)](#)
- [Individual Record Logic](#)
  - [Summary](#)
  - [Functional Requirements - A Record](#)
    - [Reporting Population](#)
  - [Reporting Population and Business Rules - A Record](#)
  -

CAMPUS STATE SPECIFIC LOCALIZATIONS - VA - MASTER SCHEDULE (MSC)

- [Report Data Elements - A Record](#)
- [B Record](#)
- [Description](#)
  - [Summary](#)
- [Functional Requirements - B Record](#)
  - [Reporting Population](#)
- [Reporting Population and Business Rules - B Record](#)
- [Report Data Elements - B Record](#)
- [C Record](#)
- [Description](#)
  - [Summary](#)
- [Functional Requirements - C Record](#)
  - [Reporting Population](#)
  - [C/ F Shared Selection Criteria](#)
- [Reporting Population and Business Rules - C Record](#)
- [Report Data Elements - C Record](#)
  - [Deprecated/ Removed Elements - C Record](#)
- [Appendices - C Record](#)
  - [Appendix A: SCED data vs Course State Code](#)
  - [Appendix B: SOL Assessment Codes](#)
- [D Record](#)
- [Description](#)
  - [Summary](#)
- [Functional Requirements - D Record](#)
  - [Reporting Population](#)
  - [Functional Requirements and Business Rules - D Record](#)
- [Reporting Population and Business Rules - D Record](#)
- [Report Data Elements - D Record](#)
  - [Deprecated/ Removed Elements - D Record](#)
  - [Appendix A: Effective Date visualization](#)
- [E Record](#)
- [Description](#)
  - [Summary](#)
- [Functional Requirements](#)
  - [Reporting Population](#)
- [Reporting Population and Business Rules - E Record](#)
- [Report Data Elements - E Record](#)
-

CAMPUS STATE SPECIFIC LOCALIZATIONS - VA - MASTER SCHEDULE (MSC)

- [Appendices - E Record](#)
  - [Appendix A: Effective Date visualization](#)
- [F Record](#)
  - [Summary](#)
- [Functional Requirements](#)
  - [Reporting Population](#)
  - [C/ F Shared Selection Criteria](#)
- [Reporting Population and Business Rules - F Record](#)
- [Report Data Elements - F Record](#)
- [Appendices - F Record](#)
  - [Appendix A: Local Provider ID \(DE3\) logic](#)
- [G Record](#)
  - [Summary](#)
- [Functional Requirements](#)
  - [Reporting Population](#)
- [Reporting Population and Business Rules - G Record](#)
- [Report Data Elements - G Record](#)
- [I Record](#)
  - [Summary](#)
- [Functional Requirements](#)
  - [Reporting Population](#)
- [Reporting Population and Business Rules - I Record](#)
- [Report Data Elements - I Record](#)
- [Summary](#)
- [Functional Requirements](#)
  - [Reporting Population](#)
- [Reporting Population and Business Rules - J Record](#)
- [Report Data Elements - I Record](#)
- [Report Design/layout](#)
- [Appendix A - Data Setup](#)

## Version Control

Version	Date	Author(s)	Brief Description of Change
1.0	10/25	<a href="#">Collette Hoppe</a>	Initial Version

## Purpose

The purpose of this FRD is to pull all information for the MSC report including overview, summary information, record linking and validation, and specifications for each individual Record into a single document for the express purpose of exporting to PDF to gather feedback and/or buy-in on logic changes from the VA Focus Group.

## Disclaimer

©2012 Infinite Campus, Inc. All rights reserved.

INFINITE CAMPUS and the INFINITE CAMPUS logo are the trademarks of Infinite Campus, Inc. This publication, or any part thereof, may not be reproduced or transmitted in any form or any means, electronic or mechanical, including photocopying, recording, storage in an information retrieval system, or otherwise, by anyone other than Infinite Campus, Inc. without written permission of Infinite Campus, Inc., 4321 109<sup>th</sup> Ave NE, Blaine, MN 55449, tel. (651) 631-0000, email [info@infinitecampus.com](mailto:info@infinitecampus.com).

## Summary, Overview, & Record Linking

### Summary:

#### **Product Version**

District Edition

#### **File Name Convention**

MMDDYYYY.ext

Where date is date report is generated.

#### **Reporting Year**

Report can be run in the active year and past years

#### **Reporting Scope**

The report can be run for a single calendar within the district or multiple calendars at a time.

## Record Types

### Summary

<b>A</b>	Header	A header record with details of the other Record Types selected
<b>B</b>	IPAL (Teaching Staff and Administrators)	<p>Includes a record for each teacher in the section into which the student is scheduled. Reports only one record for each teacher, regardless of the number of sections or courses they teach, the number of Credential or employment records, or the number of calendars. License Number is not necessary for a teacher to report.</p> <p>A record also generates for each staff member with a District Assignment record active on or before the Effective Date that has a Type of 07 or 08.</p> <p>No record reports if the Assignment Code is Null or section Staff History Role is O: Other on all sections the teacher is assigned to.</p> <p>B records do NOT report for individuals with a Provider code of 1, 2, 3, or 5 (Census &gt; People &gt; District Assignment &gt; Provider Description).</p>
<b>C</b>	Course Sections	Reports Course sections with at least 1 reportable student active on the course roster on the Effective date
<b>D</b>	Teachers	<p>Includes a record for each teacher of a reported course section.</p> <p>Reports only one record for each Teacher with an Active Teacher Role on the Effective Date.</p> <p>A teacher with Role of O: Other is excluded</p>
<b>E</b>	Other Providers (non-licensed teachers, non-teaching providers)	<p>Includes a record single record for each non-licensed teacher and/or non-administrator who teaches a reported course section</p> <p>A teacher with Role of O: Other on all sections they teach is excluded</p>

E	Students (scheduled into course sections)	<p>Includes a record for each student connected to the combination of section and teacher.</p> <p>For non-CTE Courses, students must be scheduled into the course for 20 hours or more on or before the report's Effective Date.</p> <p>If a course section is a CTE Course (has a Perkins Code entered), a record reports for each course regardless of scheduled hours. The record excludes students who have dropped a reported CTE course prior to the extract Effective Date.</p> <p>No record reports if section Staff History Role is O: Other unless the teacher is the Primary Teacher of the section. Primary Teachers report for any Role code.</p> <p>Students report once per section unless they work directly with a secondary teacher as indicated by a Roster Verification.</p>
G	Administrators	Includes a record for Administrators reported in the B Record with additional information
I	Connection Record (Perkins Code sections and connected sections)	Reports a record for each CTE course
J	Co-op	Reports a record for each CO: Co-op course

### Record Linking and DOE Validation

Record linking and validation is performed upon upload to the VDOE system. No validation between records is performed in Infinite Campus.

### Big Picture

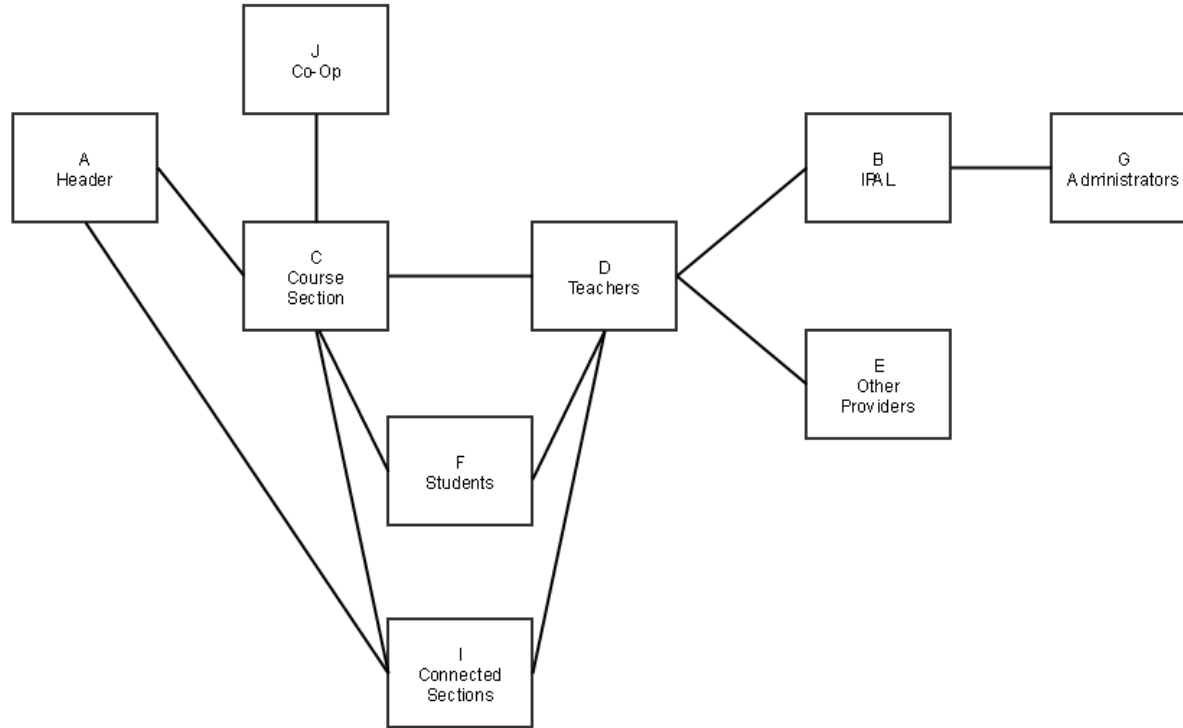

### B and G Records

B and G Records link with a one to one ratio on Local Provider ID. When the report is run for the entire district, there will only one of each record per an individual Staff person. Both Teachers and Administrators are included in both records

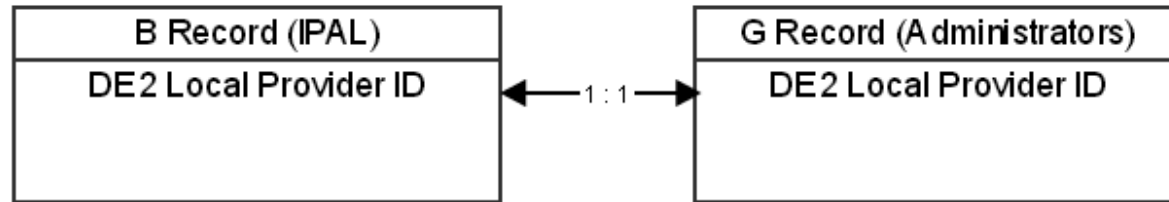

**C to A**

C Records are linked to the A Record by the Serving Division number on the Course Section to the Division number reporting the courses.

If a District is keeping track of courses students are taking in other divisions, best practice is to exclude those Courses (at the Course level) from State Reporting so they do not appear on the MSC report

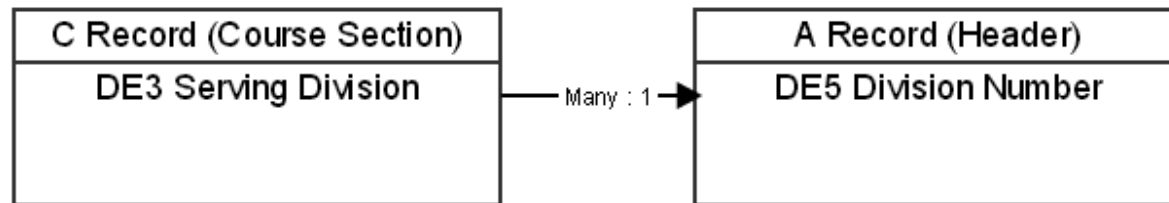

**C to D**

A course section must have at least one teacher in order to report

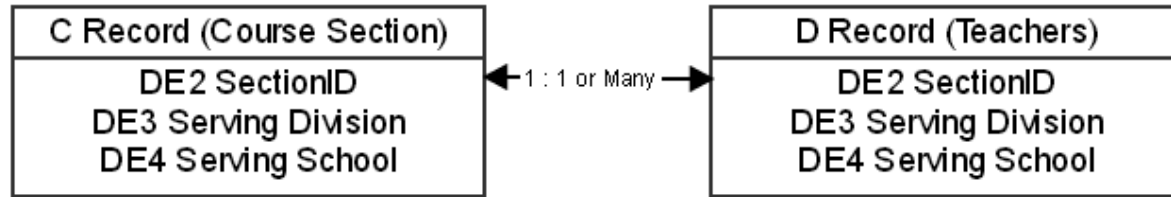

**C to F**

A course section must have at least one student to report

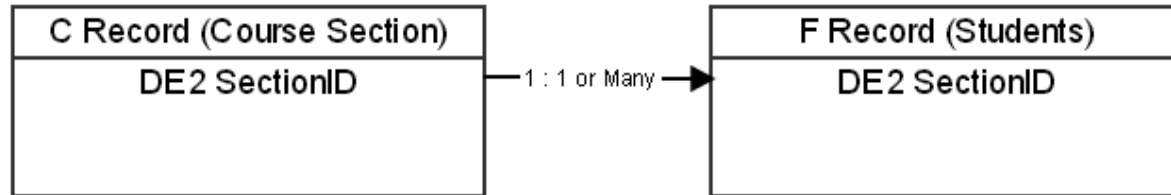

**D to (E or B)**

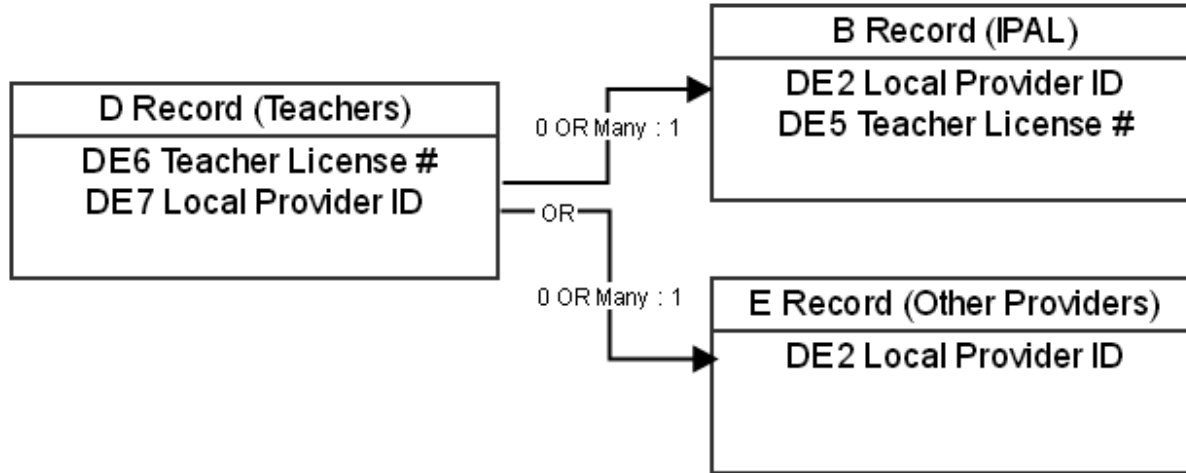

**E to D**

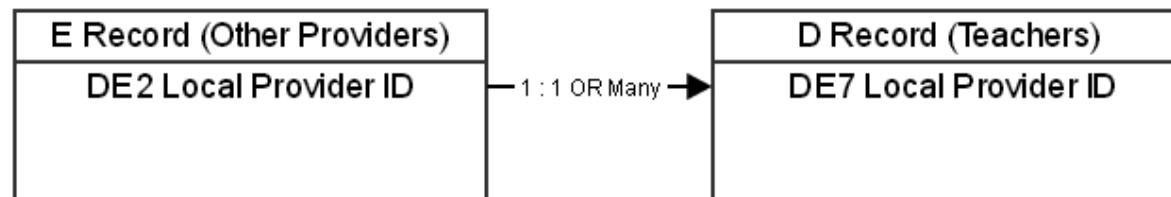

**F to D**

Students in a course section must be linked to at least one teacher of that course section

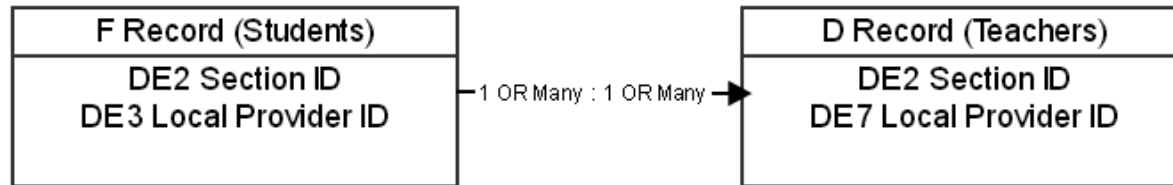

## Due Dates

Specific Dates Vary from year to year.  
EOY: July

Fall: November

### Special Notes

**The single Extract Editor is used for the VA Master Schedule Extract for all record types.**

**Header Requirements**

**Special Notes**

**This is the single Header used for the VA Master Schedule Extract for all record types, including the A Record - Header.**

**Header Format:**

SenderID=<division number="">

CreateDate=<current date="" mm="" d="" yy="">

CreateTime=<current time="" hh:mm:ss="">

Email=<sender's email="">

~~

DATATYPE=<MSC\_FALL> - This will change based on the options selected on the report editor

Use: <MSC\_FALL> when Record Type = Fall

<MSC\_EOY> when Record Type = EOY

~

#	Data Element Label	Business Rules	Data Source/GUI path	Format
HE1	SenderID	<ol style="list-style-type: none"> <li>1. Report the State District Number</li> <li>2. Report 3 digits including leading zeros</li> </ol>	System Administration > Resources > District Information > State District Number	SenderID=###

CAMPUS STATE SPECIFIC LOCALIZATIONS - VA - MASTER SCHEDULE (MSC)

HE2	CreateDate	<ol style="list-style-type: none"> <li>1. Report the System date</li> <li>2. Report in mm/dd/yyyy format</li> </ol>	System generated	CreateDate=mm/dd/yyyy
HE3	CreateTime	<ol style="list-style-type: none"> <li>1. Report the System time</li> <li>2. Report in hh:mm:ss format</li> </ol>	System generated	CreateTime=hh:mm:ss
HE4	Email	<p>The user will be responsible for updating this information</p> <p>Report element even though it is not populated with a value</p>	N/A	Email=
HE5	"Two Tildes"		System generated	~~
HE6	DATATYPE	<p>Depending what Report Type is selected on the extract editor use:</p> <p>MSC_FALL when Record Type = Fall</p> <p>MSC_EOY when Record Type = EOY</p>	See Logic	DATATYPE=MSC_collection
HE7	"One Tilde"			~

**Footer Requirements**

**Special Notes**

This is the footer used for the VA Master Schedule Extract for all record types, including the A Record - Header.

**Footer Format:**

RecordCount=###

#	Requirement
FR1	At the end of the file on the next row available report the footer
FR1.BR1	Report a single footer regardless of number of Records selected to be generated in the Extract Editor
FR2	Report "RecordCount=#####" where the # is the total number of records in the entire file generated (Not just A Records).
FR2.BR1	Report without spaces

**C/ F Shared Selection Criteria**

	Students (F Records)		At least 1 non-excluded
Course / Section (C Records)	CTE	In Progress*	Scheduled
non-excluded		Completed*	Scheduled
		Future*	Scheduled as of the Section Start Date
	Non-CTE	In Progress*	Scheduled 20+ hours*
		Completed*	Scheduled 20+ hours*
		Future*	No Sections or Students Reported

\*As of the Effective Date of the report.

Students who meet the criteria during an active portion of the course section but drop prior to the report Effective Date still report

**Teacher of Record (B/D/E/F)**

The Master Schedule Collection reports Teachers based on a Teacher of Record/ Accountability model. Using the Effective Date of the report or the last instructional date, a teacher or co-teaching team is identified on a Course Section as the Teacher accountable for the students enrolled in that section.

**Scenarios**

#	Scenarios	Results
S1	Multiple teachers teach the course at the same time as a co-teaching team	The teachers report based on their role code.
S2	<p>A main Primary teacher works with the entire roster and another teacher works with only certain students in the course</p> <ul style="list-style-type: none"> <li>This scenario needs to be indicated with appropriate role codes AND requires a Roster Verification</li> </ul>	<p>All students report for the main Primary teacher.</p> <p>The students associated with the second teacher via the Roster Verification are also reported for that teacher</p>
S3	The teacher of record leaves part way through the duration of the course	Active teacher of record is reported based on Effective Date
S4	No teacher of record can be identified	No teacher will report for the section and it is expected the districts will get errors upon uploading the file to the State. This is expected for the district to be able to audit, maintain, and correct their own data.

## Individual Record Logic

### A Record

#### Description

##### Summary

Functional Requirements - A Record

##### Reporting Population

A single record reports for the A Record with District level information

##### Reporting Population and Business Rules - A Record

#	Requirement
R1	An option exists in the Master Schedule Extract to generate A Records
R2	The A Records are generated from a shared Master Schedule Extract Editor
R2. BR1	The A Records can be generated with an other combination of MSC Records
R3	Only 1 A Record will report for each unique school year the extract is generated for, even if multiple calendars are selected within that school year
R4	The A Records will report in accordance with the Report Element Layout and Business Rules
R5	Fixed Width is the state format. This is different from the rest of the formats.

Report Data Elements - A Record

#	Data Element	State Description	Business Requirement /Business rules	Data Source/ Database Location	Database Field	Format	Length
DE1	Record Type	Constant A	1. Report 'A'	n/a	n/a	Alpha	1
DE2	Data Collection Name		1. Report 'MSC_IPAL'	n/a	n/a	Alpha	8
DE3	File Submission Type	Code to describe the submission	1. If Extract Type in the Extract Editor = Fall, Report '1' 2. If Extract Type in the Extract Editor = EOY, Report '3'	VA State Reporting > Master Schedule > Extract Type	n/a	Numeric  Valid Values:  Fall = 1  EOY = 3	1
DE4	Beginning School Year	Four-digit year for beginning of school	1. Report the four digit start year for the school year being reported from the Calendar(s) selected in the Extract Editor  Example: Report '2004' for the 2004-2005 school year	VA State Reporting > Master Schedule > Calendar(s) selected  System Administration > Calendar > Calendar > School Years > Start Year	calendar. endYear - 1	Numeric	4

CAMPUS STATE SPECIFIC LOCALIZATIONS - VA - MASTER SCHEDULE (MSC)

DE5	Division Number	A valid Edagency_num. Leading zero(s) must be included, i.e. 005	1. Report the State District Number of calendar being reported	School & District Settings > District Information > State District Number	district. number	Alphanumeric	3
DE6	Section Type	Code to describe the data included in the submission	<ol style="list-style-type: none"> <li>1. Report the alpha value of all Record(s) selected from the Records option in the Extract Editor</li> <li>2. Concatenate the values and report in alphabetical order without spaces in between</li> <li>3. Example: Report 'ADE' When the following Records are selected on the extract options page and generated: <ol style="list-style-type: none"> <li>a. <ol style="list-style-type: none"> <li>i. A Record - Header</li> <li>ii. D Records - Teachers</li> <li>iii. E Records - Other Providers</li> </ol> </li> </ol> </li> </ol>	VA State Reporting > Master Schedule > Record(s) selected	n/a	<p>Alpha</p> <p>(For documentation/ State submission purposes only. There are no validations requiring any of these combinations of records to be generated at one time)</p> <p>B and G records can only be submitted for Fall extract Type</p>	9 (max)

B Record

Description

**Summary**

The B record is a part of the VA Master Schedule Extract

Functional Requirements - B Record

**Reporting Population**

Reports for the B Record with Teacher and Administrator information.

Best Practice: The B Record is required for submission in the Fall. The B Record is not submitted in the EOY submission.

Reporting Population and Business Rules - B Record

#	Requirement	Location/Field
R1	A B Record will generate for the population of Teachers	
R1a	Teacher report population logic: <ol style="list-style-type: none"> <li>1. District Assignment must be checked Teacher</li> <li>2. Teacher has a staff history on section where course where state code is populated or PK course SCED number is hard coded to report</li> <li>3. Staff History Detail &gt; Role is not = O : Other or blank</li> <li>4. Teacher will report when teacher is assigned to a reported course/section and their district assignment for teacher is end dated before report generation but another assignment exists that fits reporting date. Even if the district assignment is not for a teacher or administrator.</li> </ol>	Scheduling & Courses > Section Information > Staff History
R4. BR1a	When only on district assignment, the Teaching District Assignment record must have no end date or have an End Date after the Effective Date of the report. If another district assignment of any sort exists, teacher will report if attached to a section that reports.	

CAMPUS STATE SPECIFIC LOCALIZATIONS - VA - MASTER SCHEDULE (MSC)

R4. BR4	<p>1. Exclude Assignments where Provider Description codes =</p> <table border="1" data-bbox="322 352 866 592"> <tr> <td data-bbox="322 352 365 411">1</td> <td data-bbox="365 352 866 411">Comprehensive Services Act placement</td> </tr> <tr> <td data-bbox="322 411 365 470">2</td> <td data-bbox="365 411 866 470">Multi-divisional online provider</td> </tr> <tr> <td data-bbox="322 470 365 529">3</td> <td data-bbox="365 470 866 529">LEA contract provider (on-line or not)</td> </tr> <tr> <td data-bbox="322 529 365 592">5</td> <td data-bbox="365 529 866 592">Post secondary institution</td> </tr> </table> <p>2. Exclude when staff history role = O or is blank</p>	1	Comprehensive Services Act placement	2	Multi-divisional online provider	3	LEA contract provider (on-line or not)	5	Post secondary institution	<p>Census &gt; Staff &gt; District Assignment &gt; Employment Assignment Information &gt; Provider Description</p>
1	Comprehensive Services Act placement									
2	Multi-divisional online provider									
3	LEA contract provider (on-line or not)									
5	Post secondary institution									
R5	Report only one (1) D record per individual									
R5. BR1	Only report district assignment records that are not excluded when determining which one to report. If a staff member has some district assignment records that are excluded and some that are not, one of the qualifying district assignment records that is not excluded should be used.									
R5. BR2	If multiple calendars are selected and staff has multiple eligible records, report only one (1) record when the report is run for the calendars containing those records (or district wide)									
R5. BR2a	If a single calendar is selected, a record will report from each eligible calendar.									
R5. BR4	If Staff have multiple eligible records determining which district assignment will populate the information in the record first with the district assignment with the most recent start date for all elements									
R5. BR4a	If the district assignment records have the same date, report from highest assignment id for all elements									
R6	The B Records will report in accordance with the Report Element Layout and Business Rules									

Report Data Elements - B Record

#	Data Element	State Description	Business Requirement /Business rules	Data Source/ Database Location	Database Field	Format	Length
DE1	Record Type	Constant B	1. Report 'B'	n/a	n/a	Alpha	1
DE2	Local Provider ID	Locally defined identification number must be unique within the division (i.e. employee id, teacher id, tax id) Do not use SSN for this ID	1. Report value entered in the field 2. Else, report blank	Census > Staff > Demographics > Local Staff Number	person.staffNumber	Alphanumeric	20
DE3	Teacher /Administrator License Prefix	Includes the characters preceding the dash on the teacher's license	1. Report value entered in the field 2. Else, report blank	Census > Staff > District Employment > License Prefix	employment.licensePrefix	Alpha	9
DE4	Teacher /Administrator License Number	Includes the numbers after the dash on the teacher's license	1. Report value entered in the field 2. Else, report blank	Census > Staff > District Employment > License Number	employment.licenseNumber	Alphanumeric	11

CAMPUS STATE SPECIFIC LOCALIZATIONS - VA - MASTER SCHEDULE (MSC)

DE5	Social Security Number		<ol style="list-style-type: none"> <li>1. Report when the following columns are both blank:             <ol style="list-style-type: none"> <li>a. Teacher/Administrator License Prefix</li> <li>b. Teacher/Administrator License Number</li> </ol> </li> <li>2. Else, report blank</li> </ol>	Census > People > Demographics > Soc Sec Number	identity.ssn	Alphanumeric	9
DE6	First Name		<ol style="list-style-type: none"> <li>1. Report value entered in the field</li> <li>2. Else, report blank</li> </ol>	Census > People > Demographics > First Name	identity.firstName	Alpha	30
DE7	Middle Name		<ol style="list-style-type: none"> <li>1. Report value entered in the field</li> <li>2. Else, report blank</li> </ol>	Census > People > Demographics > Middle Name	identity.middleName	Alpha	30
DE8	Last Name		<ol style="list-style-type: none"> <li>1. Report value entered in the field             <ol style="list-style-type: none"> <li>a. Else, report blank</li> </ol> </li> </ol>	Census > People > Demographics > Last Name	identity.lastName	Alpha	30
DE9	Formerly Filler 9						

CAMPUS STATE SPECIFIC LOCALIZATIONS - VA - MASTER SCHEDULE (MSC)

DE10	Ethnic Flag	Formerly Filler 10	Report <b>Y</b> , when student *Is the individual Hispanic/Latino? = Y:Yes  Else <b>N</b> , when student *Is the individual Hispanic/Latino? = N: No or blank  IF Ethnic Flag is Blank Race Ethnicity must be blank.	Census > People > Demographics > Race/Ethnicity > *Is the individual Hispanic/Latino?		A  Y/N	1
DE11	Race Ethnicity	Formerly Filler 11	Report the code calculated in the state Race Ethnicity mapped field based on the race or combination of races checked.  If Race Ethnicity is Blank Ethnic Flag must be blank	Census > People > Demographics > Person Information > Race/Ethnicity		N	2
DE12	Gender	Formerly Filler 12		Census > People > Demographics >		A	1
DE13	FTE		1. Report value entered in the in x.xx reporting format. a. Example if 100 is entered in the field, report 1.00. If 50 is entered in the field, report 0.50 2. If field is blank or 0, report 0.00	Census > Staff > District Employment > FTE Percent	employment.ftePercent	Numeric  x.xx	4

CAMPUS STATE SPECIFIC LOCALIZATIONS - VA - MASTER SCHEDULE (MSC)

DE14	Title I Funded Position		<ol style="list-style-type: none"> <li>In the District Assignment determining the record, if there is a value other than NULL or 0 for Title 1 Funding % <ol style="list-style-type: none"> <li>Report Y;</li> </ol> </li> <li>Otherwise, report N</li> </ol>	Census > Staff > District Assignment > Title 1 Funding %	employmentAssignment.titleIFundingPercent	Alpha Allowed Values: Y/N	1
DE15	High-Quality Professional Development		<ol style="list-style-type: none"> <li>Report value selected in the droplist <ol style="list-style-type: none"> <li>If NULL, report default value "Y"</li> </ol> </li> <li>Use District Employment record that has a start date on or before report effective date and an end date that is NULL or on or after report effective date <ol style="list-style-type: none"> <li>If staff has more than 1 eligible record, use most recent start date <ol style="list-style-type: none"> <li>If start date is the same use highest employmentID</li> </ol> </li> </ol> </li> </ol>	Census > Staff > District Employment	Employment.hqDevelopment	Alpha Allowed Values: Y/N	1
DE16	Filler 16	formerly Division Teaching Experience	<ol style="list-style-type: none"> <li>Report blank</li> </ol>	n/a	n/a		
DE17	Filler 17	formerly Virginia Teaching Experience	<ol style="list-style-type: none"> <li>Report blank</li> </ol>	n/a	n/a		

CAMPUS STATE SPECIFIC LOCALIZATIONS - VA - MASTER SCHEDULE (MSC)

DE18	Filler 18	formerly Years Teaching Experience	1. Report blank	n/a	n/a		
DE19	First Year Teacher Flag	The First Year Teacher Flag identifies individuals that have less than one year full-time teaching experience in a public or an accredited non-public school.	1. District Employment record start date must be on or before the report effective date a. Report Y, when Teaching Start Year is within the calendar year of the report is being run and Teaching Years Modifier is null or 0. b. Report N, when Teacher Start Year Date is within the calendar year of the report is being run and Teaching Years Modifier > 0 c. All else, report 'N'	Census > Staff> District Employment > Teaching Start Year  and Teaching Years Modifier		Alpha  Allowed Values: Y, N	1
20	Division Teaching Experience	Division Teaching Experience indicates the number of years the individual has completed teaching in the current school division.  If the teacher is in the first year of teaching number should be zero.	1. Report when staff has any district assignment where Teacher is checked, Current and historical a. When field 19, First Year Teacher Flag = Y, report 0	Census > Staff > District Assignment > Teacher checked  Census > Staff > District Employment > Teacher Start Year Date		N	2

2. When field 19, First Year Teacher Flag = N, First look Teacher Start Year Date, if populated, count all years after Teacher Start Year Date year ~~(takes the first year out of the count)~~
  - a. If Teacher Start Year Date is not populated, sum district assignments where teacher is checked.
  - b. If the number of years the individual has completed teaching is not a whole number, round down.
    - i. Ex. If a teacher has 4.75 years of teaching, then it is considered 4.
3. Count the years in each ~~one~~ ~~for each school year there is a~~ district assignment where Teacher is checked within each School Year date range, using school year date range of 07/01/yyyy-06/30/yyyy up to the Effective Date of report generation.
  - a. Sum each year ~~and~~ ~~subtract one from the sum for the total division teaching experience.~~
  - b. If the number of years the individual has completed teaching is not a whole number, round down.
    - i. Ex. If a teacher has 4.75 years of teaching, then it is considered 4.

CAMPUS STATE SPECIFIC LOCALIZATIONS - VA - MASTER SCHEDULE (MSC)

21	Total Years Teaching Experience Completed	<p>Total Years' Teaching Experience Completed indicates the total number of years the individual has completed as a teacher in any public, private, or out of state school.</p> <p>If the teacher is in the first year of teaching number should be zero.</p>	<ol style="list-style-type: none"> <li>1. Report when staff has any district assignment where Teacher is checked.             <ol style="list-style-type: none"> <li>a. When field 19, First Year Teacher Flag = Y, report 0</li> </ol> </li> <li>2. Add the number in the most recent District Employment record &gt; Teaching Modifier, if populated, add to the sum of field 20, Division Teaching Experience             <ol style="list-style-type: none"> <li>a. If blank, report the same number as field 20.</li> </ol> </li> </ol>	Census > Staff > District Employment > Teaching Modifier		N	2
----	---	---	---	--	--	---	---

CAMPUS STATE SPECIFIC LOCALIZATIONS - VA - MASTER SCHEDULE (MSC)

22	Division Administrative Experience	<p>Division Administrative Experience indicates the number of years the individual has completed as an administrator in the current school division.</p> <p>If the administrator is in the first year of administration or not completed a full year in administration as of October 1 of the current school year, this number should be zero.</p>	<p>Report when staff has a district assignment where Type = 08: Administrator</p> <ol style="list-style-type: none"> <li>1. First look Administrator Start Year Date, if populated, count all years after Administrator Start Year Date year (takes the first year out of the count)             <ol style="list-style-type: none"> <li>a. If Administrator Start Year Date is not populated, sum district assignments where Type = 08: Administrator                 <ol style="list-style-type: none"> <li>i. Count one for each school year there is a district assignment where Type = 08: Administrator within each School Year date range, using school year date range of 07/01/yyyy-06/30/yyyy up to the Effective Date of report generation.</li> <li>ii. Sum each year and subtract one from the sum for the total division Admin experience</li> </ol> </li> </ol> </li> </ol>	<p>Census &gt; Staff &gt; District Assignment &gt;Type = 08: Administrator</p> <p>Census &gt; Staff &gt; District Employment &gt; Administrator Start Year Date</p>		N	2
----	------------------------------------	--	---	---	--	---	---

CAMPUS STATE SPECIFIC LOCALIZATIONS - VA - MASTER SCHEDULE (MSC)

23	Total Years Administrative Experience Completed	<p>indicates the total number of years the individual has completed as an administrator in any public, private, or out of state school.</p> <p>If the individual has not completed a full year should be zero.</p>	<p>Report when staff has a district assignment where Type = 08: Administrator</p> <p>1. Add the number in the most recent District Employment record &gt; Administrative Year Modifier, if populated, ADD to the sum of field 22, Division Administrative Experience</p> <p>a. If blank, report the same number as field 22.</p>	<p>Census &gt; Staff &gt; District Assignment &gt;Type = 08: Administrator</p> <p>Census &gt; Staff &gt; District Employment</p>		N	2
----	---	--	--	--	--	---	---

CAMPUS STATE SPECIFIC LOCALIZATIONS - VA - MASTER SCHEDULE (MSC)

24	Division Pupil Personnel Experience	<p>indicates the number of years the individual has completed as pupil personnel in the current school division.</p> <p>If the individual has not completed a full year as pupil personnel as of October 1 of the current school year, this number should be zero</p>	<p>Staff District Assignment's Type must = 07 : Pupil Personnel Service Provider</p> <p>Report when staff has a district assignment where Type = 07: Pupil Personnel</p> <ol style="list-style-type: none"> <li>1. First look Pupil Personnel Start Year Date, if populated, count all years after Pupil Personnel Start Year Date year (takes the first year out of the count)             <ol style="list-style-type: none"> <li>a. If Pupil Personnel Start Year Date is not populated, sum district assignments where Type = 07: Pupil Personnel                 <ol style="list-style-type: none"> <li>i. Count one for each school year there is a district assignment where Type = 07: Pupil Personnel within each School Year date range, using school year date range of 07/01/yyyy-06/30/yyyy up to the Effective Date of report generation.</li> <li>ii. Sum each year and subtract one from the sum for the total division Pupil Personnel experience</li> </ol> </li> </ol> </li> </ol>	<p>Census &gt; Staff &gt; District Assignment &gt; Type = 07 : Pupil Personnel Service Provider</p> <p>Census &gt; Staff &gt; District Employment &gt; Pupil Personnel Start Year Date</p>		N	2
----	-------------------------------------	---	--	--	--	---	---

CAMPUS STATE SPECIFIC LOCALIZATIONS - VA - MASTER SCHEDULE (MSC)

25	Total Years Pupil Personnel Experience Completed	<p>Indicates the total number of years the individual has completed as pupil personnel in any public, private, or out of state school.</p> <p>If the individual has not completed a full year as pupil personnel as of October 1 of the current schools year, this number should be zero.</p>	<ol style="list-style-type: none"> <li>1. Report when staff has a district assignment where Type = 07: Pupil Personnel</li> <li>2. Add the number in the most recent District Employment record &gt; Pupil Personnel Year Modifier, if populated, to the sum of field 24, Division Pupil Personnel Experience                         <ol style="list-style-type: none"> <li>a. If blank, report the same number as field 24.</li> </ol> </li> </ol>	<p>Census &gt; Staff &gt; District Assignment &gt; Type = 07 : Pupil Personnel Service Provider</p> <p>Census &gt; Staff &gt; District Employment &gt; Pupil Personnel Year Modifier</p>		N	2
26	Filler 26		Report Blank				
27	Filler 27		Report Blank				

## C Record

### Description

### Summary

The C record is a part of the VA Master Schedule Extract

1. **Report Courses/Teachers/Students for entire year for Fall reporting period :**
2. When the VA Master Schedule Extract Type = Fall and C - Course record is selected, report all courses for the year; past, current and future.
  - a. Report all past, future and present course/sections that have at least one student rostered into the section. Section must have a teacher assigned to the section.
3. When the VA Master Schedule Extract Type = Fall and D - Teacher record is selected, keep current teacher selection logic.
  - a. Effective date of report generation will be used to find the current teachers/staff and students for courses that are in progress as of Effective Date.
  - b. If the course section is over as of effective date, report latest primary teacher
    - i. If no primary teacher, report teacher.
      1. If no teacher, do not report (report population logic for course, C record)
  - c. Report teachers in course sections that are active after the effective date of report generation
4. When the VA Master Schedule Extract Type = Fall and F - Student record : For course/sections in session as of the effective date, report students rostered in the section at the time of report generation
  - a. Do not report students who have dropped the course before the of Effective date unless they have a grade associated with any of the course's grading task/standard
  - b. Courses that are completed before the effective date of report generation, report only the students who have a grade associated with any of the course's grading task/standard
5. When the VA Master Schedule Extract Type = Fall and F - Student record : For non CTE course/sections active after the effective date, report students rostered in the sections. These students would have no grading tasks yet.
  - a. For courses/sections active after the effective date and Course> Perkins Code is populated (CTE), limit the number of student records reported in the future CTE course/sections to the number in the Max Students textbox. There is no need for logic as to whom should be not be reported, exclude whomever you like.
    - i. First look to Section > Max students and only report that number of students if more are rostered than the max student number, if null
      1. Look at Course > Max students and only report that number of students for each section where Max Student is null, if null
        - a. Look at Course Master > Max students and only report that number of students for each section of the course
          - i. If all null, report the number of students in the CTE Course section
6. **Previous Reporting Date** displays when Extract Type = EOY. It is a required field.
7. When the VA Master Schedule Extract Type = EOY and F - Student record Population Logic: Report students with **any posted grade or standard** in grading tasks, even if the student dropped the class

- a. Report students who were rostered in sections that began after the Previous reporting date even if they dropped
- 8. F record, Field DE6, Final Grade report population logic : Report when reporting period = EOY
  - a. EOY : Use current logic for reporting final grade reporting from the most recent state reported grading task, in addition :
    - i. Report **the score from the most recent grading task**, if the student dropped before the effective date and has no grade in a state reported grading task
    - ii. If the student was rostered in a section where the section's start date is after the Previous reporting date used in report generation and the student dropped before section's end date and has no grade in any grading task, report W
    - iii. Report **NG**, If the student completed the course and has no state reported grading task

### Functional Requirements - C Record

#### Reporting Population

Reports for the C Record with Course information.

1. The course must have State Code populated, a teacher assigned and a student assigned for both current and future courses.
2. Fall reporting period will report past, current and future courses that have state code, teacher and student assigned.
3. EOY reporting period will report courses for the entire year along with Final Grade.
4. Pre-K courses report when Course > SCED codes = 01027, 05129, 01039, 02029, 03229, 04429, 05179, 08029, 23002. No course state code needed. These student report on the F Student record.

#### C/ F Shared Selection Criteria

If a C record reports for a Course Section, at least 1 F record will report for at least 1 student.

Students (F Records)	Fall reporting period	student must be in a section as of effective date of report generation for current a future course  courses that have finished before fall reporting date, student must have a state reported grading task to report
----------------------	-----------------------	--

#### Reporting Population and Business Rules - C Record

#	Requirement
R1	An option exists in the Master Schedule Extract to generate C Records
R2	The C Records are generated from a shared Master Schedule Extract Editor

CAMPUS STATE SPECIFIC LOCALIZATIONS - VA - MASTER SCHEDULE (MSC)

R2.BR1	The C Records can be generated with an other combination of MSC Records
R3	Report a single record for each qualifying CTE Course Section. CTE Courses are indicated with a Perkins Code (Perkins Code on the course is NOT NULL)
R3.BR2	Report a section with at least 1 scheduled, non-excluded student on the roster for the course section
R3. BR2a	For future course sections, report when a is teacher assigned or student schedule and a student rostered
R4.BR2	Report only regular course sections with at least one State Reporting Grading Task attached
R4.BR3	Report a section with at least 1 scheduled, non-excluded student on the roster for the course section
R5	Exclude all course sections of a Course marked State Exclude
R6	Report a single record per unique Section ID
R7	The C Records will report in accordance with the Report Element Layout and Business Rules

Report Data Elements - C Record

#	Data Element	State Description	Business Requirement /Business rules	Data Source/ Database Location	Format	Length
DE1	Record Type	Constant C		n/a	Alpha	1
DE2	Section ID	A locally defined number that identifies a particular section. When coupled with the division and school, Section ID creates a unique identifier for the section.	Report Section ID with the following combination : D + District Number-School Number-Course Number-Section Number (D014-1234-123456789-123)	Report Section ID with the following combination : D + District Number-School Number-Course Number-Section Number (D014-1234-123456789-123)  1. The first position will default to <b>D</b> 2. Next report fromSchool & District Settings > District Information > *State District Number, with a dash separating this number from the next number (School number)	Alphanumeric	30

			<ol style="list-style-type: none"> <li>1. The first position will default to <b>D</b></li> <li>2. Next report from School &amp; District Settings &gt; District Information &gt; *State District Number, with a dash separating this number from the next number (School number)</li> <li>3. Next report from School &amp; District Settings &gt; School Information &gt; *State School Number, with a dash separating this number from the next number (Course number)</li> <li>4. Next report from Scheduling &amp; Courses &gt; Course Information &gt; Number (local number), with a dash separating this number from the next number (Section number)</li> <li>5. Next report from Scheduling &amp; Courses &gt; Section Information &gt; Section Number.</li> </ol>	<ol style="list-style-type: none"> <li>3. Next report from School &amp; District Settings &gt; School Information &gt; *State School Number, with a dash separating this number from the next number (Course number)</li> <li>4. Next report from Scheduling &amp; Courses &gt; Course Information &gt; Number (local number), with a dash separating this number from the next number (Section number)</li> <li>5. Next report from Scheduling &amp; Courses &gt; Section Information &gt; Section Number.</li> </ol>		
--	--	--	---	--	--	--

CAMPUS STATE SPECIFIC LOCALIZATIONS - VA - MASTER SCHEDULE (MSC)

DE3	Serving Division	Three-digit state-assigned Division number that identifies the division, center or agency that provided the course (or the resource to the course) to the students	<ol style="list-style-type: none"> <li>1. Report the numbers before the dash if populated on the section being reported             <ol style="list-style-type: none"> <li>a. Left pad with zeros to make 3-digits if applicable</li> </ol> </li> <li>2. If NULL, report the State District Number             <ol style="list-style-type: none"> <li>a. Left pad with zeros to make 3-digits if applicable</li> </ol> </li> </ol>	<p>Scheduling &amp; Courses &gt; Section Information &gt; Serving Division-School</p> <p>Section.serviceDistrict</p> <p>OR</p> <p>School &amp; District Settings &gt; District Information &gt; State District Number</p> <p>district.number</p>	Alphanumeric	3
DE4	Serving School	Four-digit state-assigned School number that identifies the school, center, program, or placement that provided the course (or the resource to the course) to the students	<ol style="list-style-type: none"> <li>1. Report the numbers after the dash if populated on the section being reported             <ol style="list-style-type: none"> <li>a. Left pad with zeros to make 4-digits if applicable</li> </ol> </li> <li>2. If NULL, report the State School Number             <ol style="list-style-type: none"> <li>a. Left pad with zeros to make 4-digits if applicable</li> </ol> </li> </ol>	<p>Scheduling &amp; Courses &gt; Section Information &gt; Serving Division-School</p> <p>Section.serviceDistrict</p> <p>OR</p> <p>School &amp; District Settings &gt; District Information &gt; State School Number</p> <p>School.number</p>	Alphanumeric	4

CAMPUS STATE SPECIFIC LOCALIZATIONS - VA - MASTER SCHEDULE (MSC)

DE5	SCED Code	<p>NCES-assigned number that represents a course by it's SCED Subject Area immediately followed by its SCED Course Identifier.</p> <p>For example: Grade 3 Reading will be reported as 1043. In this instance when then SCED Subject Area = 01 and SCED Course Identifier = 043 they should be concatenated and reported as a single number.</p>	<ol style="list-style-type: none"> <li>1. Concatenate the following two fields with no spaces or other characters in between</li> <li>2. Report the code from SCED Subject Area +</li> <li>3. Report the code from SCED Course Identifier</li> </ol>	<p>Scheduling &gt; Courses &gt; Course &gt; NCES Data &gt; SCED Subject Area</p> <p>Course.scedSubjectArea</p> <p>AND</p> <p>Scheduling &gt; Courses &gt; Course &gt; NCES Data &gt; SCED Course Identifier</p> <p>Course.scedCourseId</p>	Numeric	5
DE6	filler		Report blank	n/a	n/a	
DE7	SCED Course Level	A code to convey the level of rigor of the course	Report selected code in SCED Course Level	<p>Scheduling &gt; Courses &gt; Course &gt; NCES Data &gt; SCED Course Level</p> <p>Course.scedCourseLevel</p>	<p>Alphanumeric</p> <p>Must be a valid SCED Course Level Code</p> <p>May be blank if course is an AP/IB course</p> <p>Must be alpha</p> <p>Must be one character</p>	1
DE8	filler		Report blank	n/a	n/a	

CAMPUS STATE SPECIFIC LOCALIZATIONS - VA - MASTER SCHEDULE (MSC)

DE9	SCED Sequence	Code to describe the manner in which school systems may "break up" single courses. Reporting a single course in two or more parts (i.e. 1 2) can be used to report semester grades as well as final grades in the MSC. It should not be used for state-approved CTE courses that are eligible for state funding (SEDF).	<ol style="list-style-type: none"> <li>1. If NCES SCED Sequence is filled out on the course, report the first number (<b>n</b> of <b>m</b>), then a space, then the second number (<b>n</b> of <b>m</b>):             <ol style="list-style-type: none"> <li>a. e.g. 2 of 3 reports as '2 3'</li> </ol> </li> <li>2. Otherwise, report blank</li> <li>3. If SCED Sequence is 1 1, report blank.</li> </ol>	<p>Scheduling &gt; Courses &gt; Course Information &gt; NCES Data &gt; SCED Sequence</p> <p>course.scedSequence</p>	Alphanumeric	3
DE10	VA Extended Description	Used to distinguish between two or more classes within the same SCED Course Code where the SCED does deliniate. (For example, Carpentry I, II and III would use this code since SCED only has a course code for Carpentry. Algebra I and Algebra II would not use this code because they each have an unique SCED Course Code.)	<ol style="list-style-type: none"> <li>1. Report from the Course for the record</li> <li>2. If the VA Extended Description field is populated, report the Value from the attribute</li> </ol>	<p>Scheduling &amp; Courses &gt; Course Information &gt; VA Extended Description</p>	Alphanumeric	5

CAMPUS STATE SPECIFIC LOCALIZATIONS - VA - MASTER SCHEDULE (MSC)

DE11	Associated SOL Test Code	<p>What, if any, SOL test will be administered to students enrolled in this course.</p> <p>Course that need this code are identified in the list of approved SCED Codes for Virginia</p>	<ol style="list-style-type: none"> <li>1. If the course has an Assessment attached,</li> <li>2. Check if the Assessment is a valid SOL Test Code                             <ol style="list-style-type: none"> <li>a. See <b>Appendix B</b> below for valid values and reported value</li> <li>b. If 2 tests are tied to a course, they must be in the concatenated list in <b>Appendix B</b></li> </ol> </li> <li>3. If multiple valid assessments are attached to the course, concatenate the reporting value of the two assessments with the smaller value first</li> <li>4. Otherwise, report blank</li> </ol>	Scheduling & Courses > Courses > Assessment > State Code. Reports State code number	Alphanumeric	8
DE12	filler		Report blank	n/a	n/a	
DE13	Local Course Code	The locally-assigned course code.	<ol style="list-style-type: none"> <li>1. Report the Course Number</li> </ol>	Scheduling & Courses > Course Information > Number  course.number	Alphanumeric	20
DE14	Local Course Title	The locally-defined name of the course.	<ol style="list-style-type: none"> <li>1. Report the Course Name</li> </ol>	Scheduling > Courses > Course > Name  <a href="#">course.name</a>	Alphanumeric	50

CAMPUS STATE SPECIFIC LOCALIZATIONS - VA - MASTER SCHEDULE (MSC)

DE15	Semester		<ol style="list-style-type: none"> <li>1. If the term field is filled out on the Section, report the numeric value             <ol style="list-style-type: none"> <li>a. If the term field is blank, and the term field from the parent Course is filled out, report the numeric value from that field.</li> </ol> </li> <li>2. Otherwise report blank.</li> </ol>	cheduling & Courses > Section Information > Term; Course > Term  Section.term  Course.term	Numeric  Valid values: 1-4	1
------	----------	--	--	--	-------------------------------------	---

CAMPUS STATE SPECIFIC LOCALIZATIONS - VA - MASTER SCHEDULE (MSC)

DE16	Minutes per Course		<ul style="list-style-type: none"> <li>• Find courses where Perkins Code is populated(CTE course).</li> <li>• 1.</li> </ul> <p>First report from Section &gt; Instructional Minute override</p> <p>If blank report from:each section of the CTE course (this is reported by section), sum the period minutes for each period and day the section meets for the Minutes Per Course.</p> <p>i. Ex: Section meets on 88 days of the semester in a period that is 50 minutes. 4400 would report.</p> <p>Count instructional period minutes only</p> <p>For non-CTE Courses, report blank</p>	<p>Calculated from</p> <p>Scheduling &amp; Courses &gt; Course Information &gt; Perkins Code</p> <p>Section &gt; Instructional Minute override</p> <p>OR</p> <p>Period's instructional minutes summed for length of course</p>	Numeric	5
------	--------------------	--	--	--	---------	---

CAMPUS STATE SPECIFIC LOCALIZATIONS - VA - MASTER SCHEDULE (MSC)

DE17	MOP ID	A code that identifies a course with curriculum and delivery that is provided by an approved Multi-division Online Provider	Report selected code	Course > MOP ID	Alphanumeric  3=Apex  4=BYU Independent Study  5=Chesterfield County Public Schools - CCPS Online  7=Pearson  8=EdOptions Academy	2
DE18	Interdisciplinary Flag	new 2021	Report Y when Section > Interdisciplinary Connected Section is populated  Report Y for the section reporting that is populated in the Interdisciplinary Connected Section on another section. This section does not need Interdisciplinary Connected Section populated.  Report N for all else		Y/N	1

CAMPUS STATE SPECIFIC LOCALIZATIONS - VA - MASTER SCHEDULE (MSC)

DE19	Target Language	Target Language is the language of instruction in a program or course. If the language of instruction is English, leave the field blank unless the audience of the course is English Learners. The codes used for this element are based on the NCES Language ID. For example, a Math course taught in French would be designated with code 460.	Report from Course > Course Language  Default blank  Required for K-5	Scheduling & Courses > Course Information > Course Language  1577=English 1380=Spanish 460=French 510=German 70=ASL 800=Korean 1560=Vietnamese 730=Japanese 290=Chinese 80=Arabic 1530=Urdu  Course. instructionLanguage	Numeric  4 digits or less	4
DE20	filler		Report blank	n/a	n/a	
DE21	filler		Report blank	n/a	n/a	

**Deprecated/ Removed Elements - C Record**

DE6	SCED Course Identifier	NCES-assigned number that represents general courses within the Subject Area	<ol style="list-style-type: none"> <li>1. Report code selected in the drop down selected on the course</li> <li>2. Else, report blank</li> </ol>	Scheduling > Courses > Course Editor > SCED Course ID  course.scedCourseID	Alphanumeric	3	2.0
DE7	SCED Course Level	A code to convey the level of rigor of the course	<ol style="list-style-type: none"> <li>1. Report code selected in the drop down selected on the course</li> <li>2. Else, report blank</li> </ol>	Scheduling > Courses > Course Editor > SCED Course Level  course.scedCourseLevel	Alpha	1	2.0
DE5	SCED Subject Area	NCES-assigned number that represents the general context category of the section	<ol style="list-style-type: none"> <li>1. Report code selected in the drop down selected on the course</li> <li>2. Else, report blank</li> </ol> <p>For secondary courses (SCED Subject Areas 1-22), Available Credit identifies the amount of Carnegie unit credit available. For non-secondary courses (SCED Subject Area 51-73), Grade Span indicates the grade level for which the course is appropriate. If SCED Subject Area is 1-22, reports the Grading Task Credit. If SCED Subject Area is 51-73, reports the SCED Lowest and Highest Grades, as described in the following table. Otherwise, reports blank</p>	Scheduling > Courses > Course Editor > SCED Subject Area  course.scedSubjectArea	Alphanumeric	2	2.0

CAMPUS STATE SPECIFIC LOCALIZATIONS - VA - MASTER SCHEDULE (MSC)

DE8	SCED Available Credit or Grade Span			<p>Scheduling &gt; Courses &gt; Grading Task &gt; Credit</p> <p>gradingTask Credit.credit</p> <p>OR</p> <p>Scheduling &gt; Courses &gt; Course &gt; SCED Highest and Lowest Grades</p> <p>course.sced HighestGrade course.sced LowestGrade</p>	Alphanumeric	4	2.0
DE12	VA State Course Code			<p>Scheduling &gt; Courses &gt; Course &gt; State Code</p>	Numeric	4	2.0

## Appendices - C Record

### Appendix A: SCED data vs Course State Code

1. When SCED Course ID field has a value (Scheduling > Courses > Course Editor > SCED Course ID)
  - a. Report a value in the SCED fields based on the logic indicated in the layout
    - i. scedSubjectArea
    - ii. scedCourseIdentifier
    - iii. scedCourseLevel
    - iv. scedAvailableCreditOrGrade
    - v. scedSequence
  - b. Report a blank value in the 'vaState CourseCode' column
2. When SCED Course ID field is NULL
  - a. Report a blank value in each of the SCED fields
    - i. scedSubjectArea
    - ii. scedCourseIdentifier
    - iii. scedCourseLevel
    - iv. scedAvailableCreditOrGrade
    - v. scedSequence
  - b. Report State Code value on the Course Editor in the 'vaStateCourseCode' column

### Appendix B: SOL Assessment Codes

#### Codes in Bold were added Spring 2025

Strikethroughs are no longer active.

AND t.stateCode IN

('3103','4104','5105','6106','7107','8108','8114','EOC109','EOC112','4224','~~4234~~','5225','5235','6226','~~6236~~','7227','~~7237~~','8128','8138','~~3223~~','~~3233~~','EOC220','EOC221','EOC222',

'EOC120','EOC121','EOC122','5164','8165','EOC160','EOC161','EOC162','CSH174','CSH178','EOC171','EOC172','EOC179','EOC170','~~3313~~','~~3333~~','~~4314~~','~~4334~~','5264','~~5315~~','~~5335~~','6316','~~6336~~','7317','~~7337~~','8265','~~8318~~','~~8338~~','EOC261',

'CSH274','CSH278','EOC102','EOC209','EOC270','EOC274','EOC278','~~3203~~','3673','3683','4204','4674','4684','~~5190~~','~~5205~~','5675','5685','5695','~~6206~~','6676','6686','~~7207~~','7677','7687','8191','~~8208~~','8678','8688','8698'

'3303','3323','3413','3433','4304','4324','4414','4434','5290','5305','5325','5415','5425','6306','6326','6416','6436','7307','7327','7417','7437','8308','8328','8418','8438','829  
)

CAMPUS STATE SPECIFIC LOCALIZATIONS - VA - MASTER SCHEDULE (MSC)

State Assessment Code	Description	Reported Value
CSH274	Virginia Studies	274
CSH278	Civics and Economics	278
EOC102	EOC Integrated Reading and Writing Component	102
EOC109	EOC Reading	109
	EOC English: Reading and Writing	109112
EOC112	EOC Writing	112
EOC120	EOC120: Algebra I	120
	Algebra I/Algebra II	120122
	Algebra I/Geometry	120121
EOC121	EOC121: Geometry	121
	Geometry/Algebra II	121122
EOC122	EOC122: Algebra II	122
EOC160	Earth Science	160
	Earth Science/Biology	160161
	Earth Science/Chemistry	160162
EOC161	Biology	161
	Biology/Chemistry	161162
EOC162	Chemistry	162

CAMPUS STATE SPECIFIC LOCALIZATIONS - VA - MASTER SCHEDULE (MSC)

EOC170	Virginia and United States History	170
EOC171	World History and Geography to 1500	171
EOC172	World History and Geography 1500-Present	172
EOC179	World Geography	179
EOC202	EOC Integrated Reading and Writing Component	202
EOC209	EOC Reading (2017)	209
	EOC English: Reading and Writing	209112
EOC220	Algebra I (2016)	220
EOC221	Geometry (2016)	221
EOC222	Algebra II (2016)	222
EOC261	Biology (2018)	261
EOC270	Virginia and US History (2020)	270
EOC274	Virginia Studies	274
EOC309	EOC Reading 2024	309
EOC320	Algebra 1 (2023)	320
EOC321	Geometry (2023)	321
EOC322	Algebra 2 (2023)	322
3303	Grade 3 Reading (paper)	3303
3323	Grade 3 Mathematics (paper)	3233
3413	Grade 3 Reading CAT (online)	3413

CAMPUS STATE SPECIFIC LOCALIZATIONS - VA - MASTER SCHEDULE (MSC)

3433	Grade 3 Mathematics CAT (online)	3433
3673	Quad 8 Grade 3 Reading (paper)	3673
3683	Quad 8 Grade 3 Mathematics (paper)	3683
4304	Grade 4 Reading (paper)	4304
4324	Grade 4 Mathematics (paper)	4324
4414	Grade 4 Reading CAT (online)	4414
4434	Grade 4 Mathematics CAT (online)	4434
4674	Quad 8 Grade 4 Reading (paper)	4674
4684	Quad 8 Grade 4 Mathematics (paper)	4684
5305	Grade 5 Reading (paper)	5305
5325	Grade 5 Mathematics (paper)	5325
5235	Grade 5 Mathematics CAT	5235
5264	Grade 5 Science	5264
5290	Grade 5 Integrated Reading and Writing Component	5290
5415	Grade 5 Reading CAT (online)	5415
5435	Grade 5 Mathematics CAT (online)	5435
5675	Quad 8 Grade 5 Reading (paper)	5675
5685	Quad 8 Grade 5 Mathematics (paper)	5685
5695	Quad 8 Grade 5 Science (paper)	5685

CAMPUS STATE SPECIFIC LOCALIZATIONS - VA - MASTER SCHEDULE (MSC)

6306	Grade 6 Reading (paper)	6306
6326	Grade 6 Mathematics (paper)	6326
6416	Grade 6 Reading CAT (online)	6416
6436	Grade 6 Mathematics CAT (online)	6436
6676	Quad 8 Grade 6 Reading (paper)	6676
6686	Quad 8 Grade 6 Mathematics (paper)	6686
7307	Grade 7 Reading (paper)	7307
7327	Grade 7 Mathematics (paper)	7327
7417	Grade 7 Reading CAT (online)	7417
7437	Grade 7 Mathematics CAT (online)	7437
7677	Quad 8 Grade 7 Reading (paper)	7677
7687	Quad 8 Grade 7 Mathematics (paper)	7687
8191	Grade 8 Integrated Reading and Writing Component	8191
8308	Grade 8 Reading (2017) (paper)	8308
8328	Grade 8 Mathematics (2009) paper	8328
8265	Grade 8 Science	8265
8418	Grade 8 Reading (2017) CAT (online)	8418
8438	Grade 8 Mathematics (2016) CAT (online)	8438
8678	Quad 8 Grade 8 Reading (paper)	8678

CAMPUS STATE SPECIFIC LOCALIZATIONS - VA - MASTER SCHEDULE (MSC)

8688	Quad 8 Grade 8 Mathematics (paper)	8688
8698	Quad 8 Grade 8 Science (paper)	8698

D Record

Description

**Summary**

The D record is a part of the VA Master Schedule Extract

Functional Requirements - D Record

**Reporting Population**

D Records report for teachers

1. One record will be generated for each teacher in the section the student is scheduled
2. Report the teacher(s) with an Active Teacher Role on the Effective Date
3. Teachers where Role is NULL or = O: Other will not report

Reporting Note:

Teachers without License Numbers will also generate an E Records - Other Providers. It is expected that the License Number fields on the D Records - Teachers will be blank.

**Functional Requirements and Business Rules - D Record**

Reporting Population and Business Rules - D Record

#	Requirement
R1	An option exists in the Master Schedule Extract to generate D Records
R2	The D Records are generated from a shared Master Schedule Extract Editor
R2.BR1	The D Records can be generated with an other combination of MSC Records
R3	Report the teacher(s) of record of a reported course section

CAMPUS STATE SPECIFIC LOCALIZATIONS - VA - MASTER SCHEDULE (MSC)

R3.BR1	A reported course section must meet one of the follow sets of criteria
R3.BR1.a	For CTE Courses (indicated with a Perkins Code)
R3.BR1.a.i	CTE courses must have at least one non-excluded student actively scheduled into the course at any point on or before the Effective date
R3.BR1.a.ii	In progress and completed sections report based on the report Effective Date
R3.BR1.a.iii	Future CTE course sections in the reporting year can also be reported based on using the section Start Date instead of report Effective date
R3.BR1.b	For Regular/ Non-CTE Courses (Perkins Code on the course is NULL)
R3.BR1.b.i	In progress and completed sections report based on the report Effective date
R3.BR1.b.ii	A qualifying Regular course section must have at least one State Reported Grading Task attached
R3.BR1.b.iii	A qualifying regular course section must have at least one non-excluded student scheduled for at least 20 hours of instruction as of the report Effective date
R4	Report a record for each person with an active Section Staff record on the section staff history of the course section  See Appendix A for active record scenarios
R4.BR1	If there is no active Teacher as of the Effective date of the report, look forward to the next qualifying teacher/ teaching team by next most recent Start Date
R5	Exclude individual records based on the following criteria  <i>If a single record is excluded, other records may still report for that Teacher</i>
R5.BR1	Exclude sections of a Course marked Course Exclude
R5.BR2	Exclude teachers with a Role Code of O: Other for that section

R6	The D Records will report in accordance with the Report Element Layout and Business Rules
----	---

Report Data Elements - D Record

#	Data Element	State Description	Business Requirement/Business rules	Data Source/ Database Location	Format	Length
DE1	Record Type	Constant D	1. Report 'D'	n/a	Alpha	1
DE2	Section ID	A locally defined number that identifies a particular section. When coupled with the division and school, Section ID creates a unique identifier for the section.	<p>Report Section ID with the following combination : D + District Number-School Number-Course Number-Section Number (D014-1234-123456789-123)</p> <ol style="list-style-type: none"> <li>1. The first position will default to <b>D</b></li> <li>2. Next report from School &amp; District Settings &gt; District Information &gt; *State District Number, with a dash separating this number from the next number (School number)</li> <li>3. Next report from School &amp; District Settings &gt; School Information &gt; *State School Number, with a dash separating this number from the next number (Course number)</li> <li>4. Next report from Scheduling &amp; Courses &gt; Courses &gt; Course Information &gt; Number (local number), with a dash separating this number from the next number (Section number)</li> <li>5. Next report from Scheduling &amp; Courses &gt; Courses &gt; Section Information &gt; Section Number.</li> </ol>	<p>Report Section ID with the following combination : D + District Number-School Number-Course Number-Section Number (D014-1234-123456789-123)</p> <ol style="list-style-type: none"> <li>1. The first position will default to <b>D</b></li> <li>2. Next report from School &amp; District Settings &gt; District Information &gt; *State District Number, with a dash separating this number from the next number (School number)</li> </ol>	Alphanumeric	30

				<ol style="list-style-type: none"><li>3. Next report from School &amp; District Settings &gt; School Information &gt; *State School Number, with a dash separating this number from the next number (Course number)</li><li>4. Next report from Scheduling &amp; Courses &gt; Courses &gt; Course Information &gt; Number (local number), with a dash separating this number from the next number (Section number)</li><li>5. Next report from Scheduling &amp; Courses &gt; Courses &gt; Section Information &gt; Section Number.</li></ol>	
--	--	--	--	--	--

CAMPUS STATE SPECIFIC LOCALIZATIONS - VA - MASTER SCHEDULE (MSC)

DE3	Serving Division	Three-digit state-assigned Division number that identifies the division, center or agency that provided the course (or the resource to the course) to the students	<ol style="list-style-type: none"> <li>1. Report the numbers before the dash if populated on the section being reported                             <ol style="list-style-type: none"> <li>a. Left pad with zeros to make 3-digits if applicable</li> </ol> </li> <li>2. If NULL, report the State District Number                             <ol style="list-style-type: none"> <li>a. Left pad with zeros to make 3-digits if applicable</li> </ol> </li> </ol>	Scheduling & Courses > Courses > Section Information > Serving Division-School  OR  School & District Settings > District Information > State District Number  Section.serviceDistrict	Alphanumeric	3
DE4	Serving School	Four-digit state-assigned School number that identifies the school, center, program, or placement that provided the course (or the resource to the course) to the students	<ol style="list-style-type: none"> <li>1. Report the numbers after the dash if populated on the section being reported                             <ol style="list-style-type: none"> <li>a. Left pad with zeros to make 4-digits if applicable</li> </ol> </li> <li>2. If NULL, report the State School Number                             <ol style="list-style-type: none"> <li>a. Left pad with zeros to make 4-digits if applicable</li> </ol> </li> </ol>	Scheduling & Courses > Courses > Section Information > Serving Division-School  OR  School & District Settings > School Information > State School Number  Section.serviceDistrict	Alphanumeric	4
DE5	Teacher /Administrator License Prefix	Includes the characters preceding the dash on the teacher's license Section E is required if a teacher or teaching entity does not have a valid VA License	<ol style="list-style-type: none"> <li>1. Report the value entered into text field</li> <li>2. Else, Blank</li> </ol>	Census > Staff > District Employment > License Prefix  employment. licensePrefix	Alphanumeric	9

CAMPUS STATE SPECIFIC LOCALIZATIONS - VA - MASTER SCHEDULE (MSC)

DE6	Teacher /Administrator License Number	Includes the numbers after the dash on the teacher's license Section E is required if a teacher or teaching entity does not have a valid VA License	<ol style="list-style-type: none"> <li>1. Report the value entered into text field</li> <li>2. Else, Blank</li> </ol>	Census > Staff > District Employment > License Number  employment.licenseNumber	Alphanumeric	Max 11
DE7	Local Provider Id	Locally defined identification number must be unique within the division (i.e. employee id, teacher id, tax id) Do not use SSN for this Id	<ol style="list-style-type: none"> <li>1. Report local staff number</li> <li>2. Else, blank</li> </ol>	Census > Staff > Demographics > Local Staff Number  person.staffNumber	Alphanumeric	Max 20
DE8	Teacher Role Code	A code to describe the teachers role in this section.	<ol style="list-style-type: none"> <li>1. Report the numeric code set</li> <li>2. If null, report '1' as the default</li> </ol>	Scheduling & Courses > Course > Section Information > Staff History > Role  teacher.role	Numeric	1
DE9	Defined Class Type	Formerly Assignment Codes Only codes that define the audience or recipient of the instruction can be used here Who is receiving instruction /services not what is being taught Necessary element to determine if the teacher in the section is "Highly Qualified" to teach the section	<ol style="list-style-type: none"> <li>1. <del>When a Defined Class Type value is set, only report for teachers whose District Assignment is</del> <ol style="list-style-type: none"> <li>a. <del>Special Ed checkbox is flagged</del></li> <li>b. <del>Assignment is at the school being reported</del></li> </ol> </li> <li>2. When a Defined Class Type value is set, only report for teachers who have a District Assignment</li> </ol>	Scheduling & Courses > Course > Section Information > Defined Class Type  If NULL then  Scheduling & Courses > Course Information > Defined Class Type  course.spedArea	Numeric	4

			<ul style="list-style-type: none"><li>○ teachers in these types of classes with a Defined Class Type codes of 0112, 1105, or 3100 do not need to have the “Special Ed” role check box marked and should report the Defined Class Type value<ul style="list-style-type: none"><li>■ Else Special Ed checkbox need to be flagged for all other Defined Class Types</li><li>■ If the Section does not have a Defined Class Type, then the course with a Defined Class Type code of 0112, 1105, or 3100 reports even if special ed is NOT checked, else Special Ed checkbox need to be flagged for all other Defined Class Types from the Course</li></ul></li><li>○ Assignment is at the school being reported</li><li>○ If there are more than one district assignment records at the same school, then need to check from the active assignment within the effective date of the report and has the special ed checkbox marked else oldest to newest created record that has a special ed checkbox marked and is active within the effective date</li></ul>		
--	--	--	--	--	--

CAMPUS STATE SPECIFIC LOCALIZATIONS - VA - MASTER SCHEDULE (MSC)

DE10	Filler10		report a blank field			
DE11	Filler11		report a blank field			
DE12	Filler12		report a blank field			
DE13	Filler13		report a blank field			
DE14	Filler14		report a blank field			

**Deprecated/ Removed Elements - D Record**

DE10	Highly Qualified Flag	A flag to indicate if the teacher meets the federal definition of being "Highly Qualified" in this section. (Federal core subject and Special Education only)	<p>1. Report 'Y' when the following fields match:</p> <ul style="list-style-type: none"> <li>a. Course: Endorsement(s) is the same as Credential: Endorsement AND</li> <li>b. Course: Subject Type selected is Basic Elementary Curriculum (ELEM), Special Education Content (SPED), Core Academic Subject Area (CORE) or Not Applicable AND is = to Credential: Subject Type                             <ul style="list-style-type: none"> <li>i. If Subject Type is = Core, Course: Core Academic Class = Credential: Core Subject Area</li> </ul> </li> <li>c. Else Report 'N'</li> </ul> <p>2. If the teacher is HQ in one course and not in another, each record will report Y or N based on the criteria they meet for each course</p> <p>3. For the B record, if the teacher is HQ in one course and not in another, they will only report one record as a 'Y' in this column</p> <p>4. Report Y for a teacher if they are teaching a Course or Section and the Teacher's endorsements match one of the codes mapped to the Defined Class Type on the Course/Section</p> <p>Valid codes: Y or N</p>	<p>Census &gt; People &gt; Credentials &gt; Highly Qualified &gt; Endorsement</p> <p><a href="#">Endorsement: Credential - VA</a></p> <p><b>Must =</b></p> <p>Scheduling &gt; Courses &gt; Course Editor &gt; Endorsement(s)</p> <p><a href="#">Endorsement(s): Course - VA</a></p> <p><b>AND</b></p> <p>Census&gt;People&gt;Credentials&gt;Highly Qualified &gt;Subject Type</p> <p>+</p> <p>Census&gt;People&gt;Credentials&gt;Highly Qualified &gt; Core Subject Area</p> <p><b>Must =</b></p> <p>Scheduling &gt; Courses &gt; Course Editor &gt;Subject Type</p> <p>+</p> <p>Scheduling &gt; Courses &gt;Course Editor&gt;Core Academic Class</p> <p>Defined Class type mapping Attribute:</p>	Y /N	1	2.0
------	-----------------------	---	---	--	------	---	-----

				System Administration > Custom > Attribute/ Dictionary > Definition > Defined Class Type Mapping			
DE11	Flexibility Criteria Flag	A flag to indicate if the teacher meets the federal definition of being "Highly Qualified" in this section by means of the flexibility criteria.	<ol style="list-style-type: none"> <li>1. Report 'Y' when the <i>ONLY</i> Credential for determining Highly Qualified = a Local Endorsement</li> <li>2. Report 'N' when                         <ol style="list-style-type: none"> <li>a. Highly Qualified Flag = N</li> <li>b. OR Highly Qualified = Y, but Endorsements are State Endorsements</li> </ol> </li> </ol> <p>Valid codes: Y or N</p>	Scheduling > Courses > Course Editor > Max Students; Scheduling > Courses > Section > Roster	Y /N	1	2.0

## Appendices - D Record

### Appendix A: Effective Date visualization

Start Date	End Date	Active
NULL	NULL	Yes
NULL	> Effective Date	Yes
NULL	= Effective Date	Yes
NULL	< Effective Date	NO
< Effective Date	NULL	Yes
= Effective Date	NULL	Yes
< Effective Date	= Effective Date	Yes

CAMPUS STATE SPECIFIC LOCALIZATIONS - VA - MASTER SCHEDULE (MSC)

= Effective Date	= Effective Date	Yes
= Effective Date	> Effective Date	Yes
< Effective Date	< Effective Date	NO
> Effective Date	NULL	Conditional*
> Effective Date	> Effective Date	Conditional*

E Record

Description

**Summary**

The E record is a part of the VA Master Schedule Extract

Functional Requirements

**Reporting Population**

E Records report for other providers

1. One record will be generated for each non-licensed teacher that teaches a section the student is scheduled
  - a. Census > People > District Employment > License Number = NULL
2. Report the teacher(s) with an Active Teacher Role on the Effective Date
3. Teachers where Role is NULL or = O: Other will not report
4. E records can only report 1 record per district.
  - a. If multiple calendars are selected and staff has multiple eligible records a record will generate from the district assignment with the most recent start date
  - b. If they have the same date, report from highest assignment id
  - c. If a single calendar is selected, a record will report in each eligible calendar individually.

Reporting Population and Business Rules - **E** Record

#	Requirement
R1	An option exists in the Master Schedule Extract to generate E Records
R2	The E Records are generated from a shared Master Schedule Extract Editor
R2.BR1	The E Records can be generated with an other combination of MSC Records
R3	Report non licensed teacher(s) of record on a reported course section
R3.BR1	A reported course section must meet one of the follow sets of criteria

CAMPUS STATE SPECIFIC LOCALIZATIONS - VA - MASTER SCHEDULE (MSC)

R3.BR1.a	For CTE Courses (indicated with a Perkins Code)
R3.BR1.a.i	CTE courses must have at least one non-excluded student actively scheduled into the course at any point on or before the Effective date
R3.BR1.a.ii	In progress and completed sections report based on the report Effective Date
R3.BR1.a.iii	Future CTE course sections in the reporting year can also be reported based on using the section Start Date instead of report Effective date
R3.BR1.b	For Regular/ Non-CTE Courses (Perkins Code on the course is NULL)
R3.BR1.b.i	In progress and completed sections report based on the report Effective date
R3.BR1.b.ii	A qualifying Regular course section must have at least one State Reported Grading Task attached
R3.BR1.b.iii	A qualifying regular course section must have at least one non-excluded student scheduled for at least 20 hours of instruction as of the report Effective date
R3.BR2	Report a record for each qualifying person with an active Section Staff record on the section staff history of the course section  See Appendix A for active record scenarios
R3.BR2.a	Report only non licensed teachers where Census > People > District Employment > License Number = NULL
R3.BR2.b	If there is no active Teacher as of the Effective date of the report, look forward to the next qualifying teacher/ teaching team by next most recent Start Date  Note: Do not look forward if there is an active teacher on the Effective Date, but they do not meet other
R4	Exclude individual records based on the following criteria  <i>If a single record is excluded, other records may still report for that Teacher</i>
R4.BR1	Exclude sections of a Course marked Course Exclude

CAMPUS STATE SPECIFIC LOCALIZATIONS - VA - MASTER SCHEDULE (MSC)

R4.BR2	Exclude teachers with a Role Code of O: Other for that section
R5	Report a single record per individual within the district
R5.BR1	If multiple calendars are selected and staff has multiple eligible records a record will generate from the district assignment with the most recent start date
R5.BR1.a	If the district assignment records have the same date, report from highest assignment id
R5.BR2	If a single calendar is selected, a record will report in each eligible calendar individually.
R6	The E Records will report in accordance with the Report Element Layout and Business Rules

Report Data Elements - E Record

#	Data Element	State Description	Business Requirement/Business rules	Data Source/ Database Location	Format	Length
DE1	Record Type	Constant E	1. Report 'E'	n/a	Alpha	1
DE2	Local Provider Id	Locally defined identification number must be unique within the division (i.e. employee id, teacher id, tax id) Do not use SSN for this Id	1. Report local staff number 2. Else, blank	Census > People > Demographics > Local Staff Number  person.staffNumber	Alphanumeric	Max 20
DE3	Provider Name	The name of the other provider Must be the name of a specific private school, contracting company or unlicensed individual	1. Report First and Last Name	Census > People > Demographics  First Name, Last Name  identity.firstName  identity.lastName	Alphanumeric	Max 50

CAMPUS STATE SPECIFIC LOCALIZATIONS - VA - MASTER SCHEDULE (MSC)

DE4	Provider Description	Description of the services provided	<ol style="list-style-type: none"> <li>1. Report code selected in the drop down             <ol style="list-style-type: none"> <li>a. If multiple calendars are selected and staff has multiple eligible records report from the district assignment with the most recent start date                 <ol style="list-style-type: none"> <li>i. If they have the same date, report from highest assignment id</li> </ol> </li> <li>b. If a single calendar is selected, report from the assignment associated with that calendar.</li> </ol> </li> </ol>	Census > Staff > District Assignment > Provider Description  employmentAssignment.alternateType	Numeric	1
-----	----------------------	--------------------------------------	---	---	---------	---

Appendices - E Record

**Appendix A: Effective Date visualization**

Start Date	End Date	Active
NULL	NULL	Yes
NULL	> Effective Date	Yes
NULL	= Effective Date	Yes
NULL	< Effective Date	NO
< Effective Date	NULL	Yes
= Effective Date	NULL	Yes
< Effective Date	= Effective Date	Yes
= Effective Date	= Effective Date	Yes
= Effective Date	> Effective Date	Yes
< Effective Date	< Effective Date	NO
> Effective Date	NULL	Conditional*
> Effective Date	> Effective Date	Conditional*

## F Record

### Description

#### Summary

The F record is a part of the VA Master Schedule Extract

#### Functional Requirements

#### Reporting Population

Reports for the F Record with Student information associated with Courses and the Course Teacher(s).

1. One record will be generated for each student that is connected to the combination of section & teacher regardless of enrollment type (P,S or N)
  - a. Fall report period, student must be enrolled on effective date of MSC report generation
  - b. EOY report period, student must be enrolled within report generation date. Student enrollment end date can be populated within report generation dates.
2. A second record may report for student/ section if a Roster Verification exists for a secondary teacher of the course and that student
3. Students report in completed, in progress, and future course sections for CTE Courses (course has a Perkins Code populated)
  - a. If a student has a Roster End date prior to the course start date, do not report an F record for this student.
  - b. A record will report for any student where they are scheduled in a course for 20 hours as of the effective date of the report
  - c. Divisions will no longer report MSC data for students served in a VDOE licensed Private School for Students with Disabilities (Serving division-school) does not start with '600'
    - i. Following exceptions SHOULD be included:
      1. New Community (600-701)
4. Students report in completed or in progress regular (non-CTE) course sections (Perkins Code IS NULL)
  - a. Any course a student is scheduled in that begins after the effective date will not report.
  - b. A record will report for any student where they are scheduled in a course for 20 hours as of the effective date of the report
  - c. Students who start a course after the report effective date will not report
    - i. If roster start date is after the effective date OR
    - ii. If roster start date is NULL use the lowest term start date based on section schedule placement to determine start date
5. Divisions will no longer report MSC data for students served in a VDOE licensed Private School for Students with Disabilities (Serving division-school does not start with '600')
  - a. Following exceptions SHOULD be included:
    - i. New Community (600-701)

- ii. St. Mary's (600-1241)
  - iii. The Auburn School (600-1251)
6. Student record generation is not dependent on a report-able Teacher

**C/ F Shared Selection Criteria**

If a C record reports for a Course Section, at least 1 F record will report for at least 1 student.

	Students (F Records)		At least 1 non-excluded
Course / Section (C Records)	CTE	In Progress*	Scheduled =>20 hours*
non-excluded		Completed*	Scheduled =>20 hours*
		Future*	Scheduled as of the Section Start Date. A Primary teacher must be assigned to the section for reporting future course/sections
	Non-CTE	In Progress*	Scheduled =>20 hours*
		Completed*	Scheduled =>20 hours*
		Future*	No Sections or Students Reported

\*As of the Effective Date of the report.

Students who meet the criteria during an active portion of the course section but drop prior to the report Effective Date still report

**Reporting Population and Business Rules - F Record**

#	Requirement	Database Field
R1	An option exists in the Master Schedule Extract to generate F Records	
R2	The F Records are generated from a shared Master Schedule Extract Editor	

CAMPUS STATE SPECIFIC LOCALIZATIONS - VA - MASTER SCHEDULE (MSC)

R2. BR1	The F Records can be generated with an other combination of MSC Records	
R3	Report students rostered into a non-excluded course section	
R3. BR1	<p>For CTE Courses (indicated with a Perkins Code)</p> <ol style="list-style-type: none"> <li>1. For courses/sections active after the effective date and Course&gt; Perkins Code is populated (CTE), limit the number of student records reported in the future CTE course/sections to the number in the Max Students textbox. There is no need for logic as to whom should be not be reported, exclude whomever you like. <ol style="list-style-type: none"> <li>a. First look to Section &gt; Max students and only report that number of students if more are rostered than the max student number, if null <ol style="list-style-type: none"> <li>i. Look at Course &gt; Max students and only report that number of students for each section where Max Student is null, if null <ol style="list-style-type: none"> <li>1. Look at Course Master &gt; Max students and only report that number of students for each section of the course <ol style="list-style-type: none"> <li>a. If all null, report the number of students in the CTE Course section</li> </ol> </li> </ol> </li> </ol> </li> </ol> </li> </ol>	
R3. BR1a	Report students actively scheduled in the course at any point during all course sections that are completed or in progress as of the report Effective Date	
R3. BR1b	<p>Report students scheduled to take a future course sections in the reporting year as of the section start date</p> <ul style="list-style-type: none"> <li>• Do not report students in future course sections with no primary teacher assigned.</li> </ul>	
R3. BR1c	<ol style="list-style-type: none"> <li>1. Do not report students served in a VDOE licensed Private School for Students with Disabilities. <ol style="list-style-type: none"> <li>a. Report students whose Enrollment &gt; Serving Division-School field = null</li> <li>b. Report students whose Enrollment &gt; Serving Division-School field is one of the following: <ol style="list-style-type: none"> <li>i. 600-701 (New Community)</li> <li>ii. 600-1241 (St. Mary's)</li> <li>iii. 600-1251 (The Auburn School)</li> </ol> </li> </ol> </li> </ol>	
R3. BR2	For Regular/ Non-CTE Courses (Perkins Code on the course is NULL)	

CAMPUS STATE SPECIFIC LOCALIZATIONS - VA - MASTER SCHEDULE (MSC)

R3. BR2a	A qualifying Regular course section must have at least one State Reported Grading Task attached	
R3. BR2b	For course sections completed or in progress as of the report Effective Date, report only students scheduled for at least 20 hours of instruction as of the report Effective date	
R3. BR2c	Do not report future course sections for non-CTE courses	
R4	Exclude enrollments from reporting based on the following criteria:  <i>Only search enrollments that are not excluded when determining which one to report. If a student has some enrollments that are excluded and some that are not, one of the enrollments that are not excluded should be used</i>	
R4. BR1	Exclude enrollments marked State Exclude	enrollment. stateExclude
R4. BR2	Exclude enrollments marked No Show	enrollment. noShow
R4. BR3	Exclude enrollments in a state excluded grade level	gradeLevel. excludeState
R4. BR4	Exclude all students in a Calendar marked Exclude	calendar. exclude
R5	Report one record per unique combination of student (DE4 State Testing ID), course section (DE2 Section ID), and teacher (DE3 Local Provider ID)  See Appendix A for additional logic	
R5. BR1	Report a record even if Local Provider ID is blank	
R6	The F Records will report in accordance with the Report Element Layout and Business Rules	

Report Data Elements - F Record

#	Data Element	State Description	Business Requirement /Business rules	Data Source/ Database Location	Format	Length
DE1	Record Type	Constant F	1. Report 'F'	n/a	Alpha	1
DE2	Section ID	A locally defined number that identifies a particular section. When coupled with the division and school, Section ID creates a unique identifier for the section.	Report Section ID with the following combination : D + District Number-School Number-Course Number-Section Number (D014-1234-123456789-123)	Report Section ID with the following combination : D + District Number-School Number-Course Number-Section Number (D014-1234-123456789-123)  1. The first position will default to <b>D</b> 2. Next report from School & District Settings> District Information > *State District Number, with a dash separating this number from the next number (School number)	Alphanumeric	30

			<ol style="list-style-type: none"> <li>1. The first position will default to <b>D</b></li> <li>2. Next report from School &amp; District Settings&gt; District Information &gt; *State District Number, with a dash separating this number from the next number (School number)</li> <li>3. Next report from School &amp; District Settings &gt; School Information &gt; *State School Number, with a dash separating this number from the next number (Course number)</li> <li>4. Next report from Scheduling &amp; Courses &gt; Course Information &gt; Number (local number), with a dash separating this number from the next number (Section number)</li> <li>5. Next report from Scheduling &amp; Courses &gt; Section Information &gt; Section Number.</li> </ol>	<ol style="list-style-type: none"> <li>3. Next report from School &amp; District Settings &gt; School Information &gt; *State School Number, with a dash separating this number from the next number (Course number)</li> <li>4. Next report from Scheduling &amp; Courses &gt; Course Information &gt; Number (local number), with a dash separating this number from the next number (Section number)</li> <li>5. Next report from Scheduling &amp; Courses &gt; Section Information &gt; Section Number.</li> </ol>		
--	--	--	--	--	--	--

CAMPUS STATE SPECIFIC LOCALIZATIONS - VA - MASTER SCHEDULE (MSC)

DE3	Local Provider Id	Locally defined identification number must be unique within the division (i.e. employee id, teacher id, tax id) Do not use SSN for this Id  Must match Local Provider ID reported in D Records	<ol style="list-style-type: none"> <li>1. Report local staff number for the Primary teacher of the section on the Effective Date <ol style="list-style-type: none"> <li>a. If the teacher has a role code of O:Other, they are not reported</li> </ol> </li> <li>2. If there is no active Primary Teacher on the Effective Date, report a Primary Teacher with the next most recent Start Date</li> <li>3. Otherwise, report blank</li> </ol> <p>See Appendix A for full logic</p>	Census > People > Demographics > Local Staff Number  person.staffNumber	Alphanumeric	20
DE4	State Testing Id	State Testing ID as assigned through EIMS	<ol style="list-style-type: none"> <li>1. Report the Student State ID of the student being reported</li> <li>2. Else, blank</li> </ol>	Census > People > Demographics > Student State ID  person.stateID	Numeric	10
DE5	Local Student Id	Locally Defined	<ol style="list-style-type: none"> <li>1. Report the Local Student Number of the student being reported</li> </ol>	Census > People > Demographics > Local Student Number  person.studentNumber	Numeric	12
DE6	Final Grade	Locally defined most recent or final grade for the student for this Section Id	<ol style="list-style-type: none"> <li>1. Report only when reporting period = EOY. Reports blank for fall.</li> <li>2. Report 'State Score' value mapped to the Grade/Score student earned</li> </ol>	Student Information > General > Grades; Grading & Standards > Grading Tasks > State Reported	Alpha  A+, A, A-,  B+, B, B-,  C+, C, C-,	3

			<p>a. First consider Student Information &gt; General &gt; Grades</p> <p>i. Grade must be tied to a Grading Task or Standard flagged as 'State Reported'</p>	<p>Grading &amp; Standards &gt; Score Groups &amp; Rubrics &gt; State Score</p>	<p>D+, D, D-, F = Failed, P = Passed E = Meets or exceeds expectations O = Outstanding G = Good S = Satisfactory U = Unsatisfactory N = Does not meet expectations NP = Not Passed (should not be used in place of F) W = Withdrawal WP = Withdrawal Passing</p>	
--	--	--	--	---	--	--

			<p>ii. If the student has both a State Reported Grading Task Score and State Reported Standard Score, report the Standard Score</p> <ol style="list-style-type: none"> <li>1. Grading &amp; Standards &gt; Score Groups &amp; Rubrics &gt; Score Group List Items Detail; Rubric List Items Detail</li> <li>2. Grading &amp; Standards &gt; Grading Tasks &gt; Grading Task Detail &gt; State Reported NOT NULL</li> <li>3. Grading &amp; Standards &gt; Standards Bank &gt; Standard Group Detail &gt; Standard Detail &gt; State Reported NOT NULL</li> </ol>	<p>WF = Withdrawal Failing</p> <p>NG = no grade awarded regardless of reason</p> <p>GLP = grade level promoted</p> <p>GLR = grade level retained</p>
--	--	--	---	--

			<p>b. Note: If a State Score is not mapped to the Score student receives, report the 'Score' value set in the Score Group List</p> <p>3. Report '0' if student does not have a Grade/Score</p> <p>4. When a student has a Grade, the State Score value must report as set. Example, when State Score = 'A-', report 'A-', not 'A'.</p> <p>Your agency-defined definition applies if a definition is not specifically stated below. any numeric value between 0 and 100</p>		
--	--	--	--	--	--

CAMPUS STATE SPECIFIC LOCALIZATIONS - VA - MASTER SCHEDULE (MSC)

DE7	Remote Course Indicator	<p>Indicates whether or not the course is taken via virtual means to include online courses, or courses taken via satellite between schools.</p> <p>1 = School sponsored/coordinated</p> <p>2 = Student coordinated</p> <p>3 = Blended Learning: A combination of virtual and face-to-face learning</p> <p>4 = Remote Learning that is NOT virtual</p> <p>MOP = Multi Divisional Online Program</p> <p>DLMOP = Distance Learning &amp; MOP</p>	<p>1. Report code selected from Scheduling &amp; Courses &gt; Section Information &gt; Online Course</p> <p>a. If null, report selected code from Scheduling &amp; Courses &gt; Course Information &gt; Online Course</p> <p>2. If MOP or DLMOP, Report 1.</p> <p>3. If both null, report blank.</p>	<p>1. Scheduling &amp; Courses &gt; Section Information &gt; Online Course (Override), report selected code</p> <p>2. If Section &gt; Online Course (Override) is blank, report from Scheduling &amp; Courses &gt; Course Information &gt; Online Course</p> <p>Course. distanceLearning</p>	Numeric	1
-----	-------------------------	--	--	--	---------	---

CAMPUS STATE SPECIFIC LOCALIZATIONS - VA - MASTER SCHEDULE (MSC)

DE8	Dual Enrollment Flag	Indicates whether or not the course is taken as a dual enrollment course	<p>Report as follows</p> <p>1. <del>'Y'</del> when flagged</p> <p>2. <del>'N'</del> when not flagged</p> <p>If Scheduling &amp; Courses &gt; Course Information &gt; Dual Enrollment is checked</p> <p>OR</p> <p>If Scheduling &amp; Courses &gt; Courses &gt; Section Information &gt; Instruct Setting /Work-Basd Learning = 99: Dual Enrollment</p> <p>OR</p> <p>If Scheduling &amp; Courses &gt; Courses &gt; Section Information &gt; Section Roster Batch Edit &gt; Instructional Setting Override = 99: Dual Enrollment</p> <p>Then Y</p> <p>Else N</p>	<p>Scheduling &gt; Course &gt; Dual Enrollment</p> <p>Scheduling &amp; Courses &gt; Courses &gt; Section Information &gt; Instruct Setting/Work-Basd Learning</p> <p>Scheduling &amp; Courses &gt; Courses &gt; Section Information &gt; Section Roster Batch Edit &gt; Instructional Setting Override</p>	Alpha Y/N	1
-----	----------------------	--	--	--	--------------	---

CAMPUS STATE SPECIFIC LOCALIZATIONS - VA - MASTER SCHEDULE (MSC)

DE9	Work-Based Learning Code	Work-based learning is defined as a coordinated, coherent sequence of career-development experiences, based on instructional preparation, related to students' career interests or goals.	<p>1. If course type not = Co : Co-op, First look to the Roster Batch Edit &gt; Instructional Setting and report selected code</p> <p>a. If null look to Scheduling &amp; Courses &gt; Section Information &gt; Instructional Setting</p>	<p>Roster Batch Edit &gt; Instructional Setting and report selected code</p> <p>Scheduling &amp; Courses &gt; Section Information &gt; Instructional Setting</p> <p>Section. instructionalSetting</p>	Numeric	1
DE10	Governor's Academy Code	Indicates whether or not the course taken is at a Governor's Academy	Report Blank		Alpha	1
DE11	Responsible Division		<p>Report the left leading 3 digits in front of the dash, from Responsible Division /School drop list in state reporting fields. <del>in any school where District Information Detail &gt; Type = RG</del></p> <p><del>District Information Detail &gt; Type = RG</del></p> <p>if less than 3 zero pad on left for a length of 3,</p> <p>1. All else report from Division Information 2. Blanks no longer allowed.</p>	<p><del>District Information Detail &gt; Type = RG</del></p> <p>District Information &gt; State District Number</p> <p>Enrollment. responsibleDivSchool</p>		

CAMPUS STATE SPECIFIC LOCALIZATIONS - VA - MASTER SCHEDULE (MSC)

DE12	Credit Awarded Flag		<p>Report in reporting period = Fall and EOY.</p> <ol style="list-style-type: none"> <li>1. Report Y, when the associated course has a transcript entry where Credit Earned is greater than 0.               <ol style="list-style-type: none"> <li>a. If the Final Grade on the Transcript is NG, W, WP, WF or F then report the credit awarded flag as N                   <ol style="list-style-type: none"> <li>i. example: If the Final Grade is 'A', 'B', 'C', 'D', 'P' then reports the credit awarded flag as Y</li> </ol> </li> </ol> </li> <li>2. If no transcript entry, report N</li> <li>3. Report N when a student has a passing transcript entry for a course where the Credit Type on the state-reported Grading Task used for reporting has a State Code = NC on the associated Credit Group</li> </ol>	Associated transcript for course/section.	Alpha	1
DE13	<del>50% Course Enrollment Flag</del>  Filler13	<del>A flag that indicates that the student was enrolled in the course 50% or more of the term reported</del>	<del>Report Y if student was enrolled for 50% or more of the rostered course.</del>  <del>Report N if less than 50%</del>	<del>Compare student roster to section schedule placement to calculate enrollment flag</del>	Alpha	4

CAMPUS STATE SPECIFIC LOCALIZATIONS - VA - MASTER SCHEDULE (MSC)

DE14	Responsible School	Indicates the responsible school of the student.	<ol style="list-style-type: none"> <li>1. Report the numbers after the dash if populated on enrollment                             <ol style="list-style-type: none"> <li>a. Left pad with zeros to make 4-digits if applicable</li> </ol> </li> <li>2. If NULL, report the State School Number                             <ol style="list-style-type: none"> <li>a. Left pad with zeros to make 4-digits if applicable</li> </ol> </li> </ol>	Student Information > General > Enrollments > Responsible Division-School  if NULL then  School & District Settings > District Information > State School Number	Alpha	4
DE15	Class Periods Present	Class Period Present is the number of days the student physically or virtually attended class. A student must be present for instruction to be included (if a student is not in class due to a field trip, they should be marked absent for that class period).	Report Blank			
DE16	Class Periods Absent	Class Period Absent is the number of days the student was absent and missed instruction. A student must have class membership and not be present to be considered absent.	Report Blank			
DE17	Career Pathways Dual Enrollment	Indicates college coursework taken by high school students under an agreement between a public school or public school division and a VCCS college or university. Wherein a student takes college-level coursework through a career technical educational pathway that provides the opportunity to complete a Career Studies Certificate which does not require general education coursework.	Report N			
DE18	Filler18					

CAMPUS STATE SPECIFIC LOCALIZATIONS - VA - MASTER SCHEDULE (MSC)

DE19	Filler19					
------	----------	--	--	--	--	--

**Appendices - F Record**

**Appendix A: Local Provider ID (DE3) logic**

#	Description	Database field(s)
R1	The Local Provider ID for a course will populate on the student's record based on the section's Staff History with the Primary Teacher of the course	
R1. BR1	Teachers that were an active instructor of the course as of the report effective date will be considered for determining Local Provider ID	SectionStaffHistory.staffType SectionStaffHistory.startDate SectionStaffHistory.endDate
R1. BR1a	In cases where there is no active Teacher on the course as of the report effective date, future teachers will be considered	SectionStaffHistory.startDate
R1. BR1b	Primary teachers, section staff or other Teachers on the section must have a valid Role code to be considered	SectionStaffHistory.role
R1. BR1c	The F Record must contain students for the section for each active teacher of the course/section on the effective date with a teach role code of 1 or 4	
R1. BR1bi	Primary Teachers, Section staff or other Teachers on the section with a Teacher Role of NULL or = O: Other will NOT populate the Local Provider ID	SectionStaffHistory.role
R1. BR2	If there is a Primary Teacher of the section, they will populate for Local Provider ID first	SectionStaffHistory.staffType
R1. BR3	A section staff member or other Teacher (non-Primary teacher) may populate for the Local Provider ID if there is no active Primary Teacher as of the report effective date	SectionStaffHistory.staffType
R1. BR3. a	Section staff or other Teachers on the section with a Teacher Role of NULL or = O: Other will NOT populate the Local Provider ID	SectionStaffHistory.role

CAMPUS STATE SPECIFIC LOCALIZATIONS - VA - MASTER SCHEDULE (MSC)

R1. BR4	If there is no teacher active as of the report effective date, the Local Provider ID will consider the next active teacher after the effective date by most recent Start Date	SectionStaffHistory.startDate SectionStaffHistory.endDate
R1. BR5	If there is no Primary Teacher, but multiple section staff/ other teachers report first from the most recently active Teacher by End date. If the Teachers have the same dates on the Section Staff history, report first from the person with the lowest Person ID.	SectionStaffHistory.staffType SectionStaffHistory.startDate SectionStaffHistory.endDate SectionStaff.personID
R2	A second F record will be created for the student if a Course section has a Section staff or other Teacher who gives instruction to that specific student and the instructor does not work with the entire roster of the course section.	
R2. BR1	If the teacher/ section staff has a role code: 1, 4, 6, 7 then check if there is a Roster Verification completed for that staff person for the course section	SectionStaffHistory.role
R2. BR1. a	The Roster Verification must have a State Code of 01: MSC - End of Year	RosterVerificationRequest.code
R2. BR1. b	The Roster Verification must be certified	RosterVerificationSectionStaff. completed
R2. BR1.c	The Roster Verification must associate the instructor with at least one (1) student on the roster, but not the entire roster of students (<100%)	RosterVericiationSectionStudent. amount
R2. BR2	For each student associated with the staff person via the Roster Verification, if Instruction Time greater than zero (> 0) / Not NULL, a second F record will generate for the student with the Local Provider ID populated from the instructor indicated via the Roster Verification	RosterVericiationSectionStudent. amount
R2. BR3	If the teacher/ section staff does not have one of the above role codes, a second F record will NOT generate for the student for that course section	

CAMPUS STATE SPECIFIC LOCALIZATIONS - VA - MASTER SCHEDULE (MSC)

R2. BR4	If a qualifying Roster Verification does not exist, a second F record will NOT generate for the student for that course section	
------------	---	--

## G Record

### Description

#### Summary

The G record is a part of the VA Master Schedule Extract

#### Functional Requirements

#### Reporting Population

G Records report for Administrators

1. Report staff who have a District Assignment record where the dates fall on or before the Effective Date of the report in the year being reported AND Type = 07: Pupil Personnel Service Provider, 08: Administrator, or 10 : Other Staff not connected to a section and Assignment Code cannot be blank.
  - a. If Assignment Code = NULL and Type = 07, 08 or 10, do not report staff member on the G Record
    - i. Census > People > District Assignment

#### Reporting Population and Business Rules - G Record

#	Requirement
R1	An option exists in the Master Schedule Extract to generate G Records
R2	The G Records are generated from a shared Master Schedule Extract Editor
R2.BR1	The G Records can be generated with an other combination of MSC Records
R	The G Records will report in accordance with the Report Element Layout and Business Rules

Report Data Elements - G Record

Seq	#	Data Element	State Description	Business Requirement /Business rules	Data Source/ Database Location	Format	Length
1	DE1	Record Type	Constant G	1. Report 'G'	n/a	Alpha	1
2	DE2	Local Provider Id	Locally defined identification number must be unique within the division  Must match the Local ID reported in B	1. Report local staff number 2. Else, blank	Census > People > Demographics > Local Staff Number  person.staffNumber	Alphanumeric	Max 20
3	DE3	Serving Division	Three-digit state-assigned Division number that identifies the division, center or agency that provided the course (or the resource to the course) to the students	1. Report the numbers before the dash if populated on the section being reported a. Left pad with zeros to make 3-digits if applicable 2. If NULL, report the State District Number a. Left pad with zeros to make 3-digits if applicable	Scheduling & Courses > Section Information > Serving Division-School  OR  School & District Settings > District Information > State District Number  district.number	Alphanumeric	3

CAMPUS STATE SPECIFIC LOCALIZATIONS - VA - MASTER SCHEDULE (MSC)

4	DE4	Serving School	Four-digit state-assigned School number that identifies the school, center, program, or placement that provided the course (or the resource to the students)	<ol style="list-style-type: none"> <li>Report the numbers after the dash if populated on the section being reported                             <ol style="list-style-type: none"> <li>Left pad with zeros to make 4-digits if applicable</li> </ol> </li> <li>If NULL, report the State School Number                             <ol style="list-style-type: none"> <li>Left pad with zeros to make 4-digits if applicable</li> </ol> </li> </ol>	Scheduling & Courses > Section Information > Serving Division-School  OR  School & District Settings > School Information > State School Number  school.number	Alphanumeric	4
5	DE5	Teacher /Administrator License Prefix	Includes the characters preceding the dash on the teacher's license Section E is required if a teacher or teaching entity does not have a valid VA License	<ol style="list-style-type: none"> <li>Report the value entered into text field</li> <li>Else, Blank</li> </ol>	Census > Staff > District Employment > License Prefix  employment.licensePrefix	Alphanumeric	4
6	DE6	Teacher /Administrator License Number	Includes the numbers after the dash on the teacher's license Section E is required if a teacher or teaching entity does not have a valid VA License	<ol style="list-style-type: none"> <li>Report the value entered into text field</li> <li>Else, Blank</li> </ol>	Census > Staff > District Employment > License Number  employment.licenseNumber	Alphanumeric	Max 11
7	DE7	Teacher Role Code	A code to describe the teachers role in this section.	<ol style="list-style-type: none"> <li>Report 07, 08 or 10</li> </ol>	Census > Staff > District Assignment > Type  teacher.role	Numeric	1

CAMPUS STATE SPECIFIC LOCALIZATIONS - VA - MASTER SCHEDULE (MSC)

8	DE8	VA State Assignment Code	4-digit valid course code from list of assignment codes	<ol style="list-style-type: none"> <li>Report code selected from the Assignment Code drop down if Type is set to 07: Pupil Personnel Service Provider, 08: Administrative or 10: Other staff not connected to a section.</li> <li>Else, blank</li> </ol>	Census > Staff > District Assignment > Assignment Code  EmploymentAssignment.assignmentCode		Max 4
9	DE9	Filler9	formerly Division Administrative Experience	report a blank field			
10	DE10	Filler10	formerly Virginia Administrative Experience	report a blank field			
11	DE11	Filler11	formerly Years Administrative Experience	report a blank field			
12	DE15	First Year Administrator Flag	First Year Administrator Flag identified if an individual has less than one year full-time experience in their current role in a public or an accredited non-public school.	<ol style="list-style-type: none"> <li>Calculate from the District Employment record that has a start date on or before the report effective date</li> <li>If the Administrator start date is within the calendar year the report is being run for, report "Y" <ol style="list-style-type: none"> <li>Otherwise, report "N"</li> </ol> </li> </ol>	Census > Staff > District Employment		Alpha  Allowed Values: Y, N
13	DE13	Filler13		report a blank field			
14	DE14	Filler14		report a blank field			

## I Record

### Description

#### Summary

The I record is a part of the VA Master Schedule Extract

#### Functional Requirements

#### Reporting Population

I Records report to connected course sections

1. Only report connected CTE courses indicated by courses with a Perkins Code
  - a. If [VA - Connected Section](#) field is populated, report the Section ID entered in this field in column 4: SectionID and report the SectionID of the section being reported in column 5 as the Connected Section ID
  - b. Only courses in the same calendar will report. Sections reported on the I record must also have a corresponding C record in the same calendar.

#### Reporting Population and Business Rules - I Record

#	Requirement
R1	An option exists in the Master Schedule Extract to generate I Records
R2	The I Records are generated from a shared Master Schedule Extract Editor
R2.BR1	The I Records can be generated with an other combination of MSC Records
R	The I Records will report in accordance with the Report Element Layout and Business Rules

Report Data Elements - I Record

#	Data Element	State Description	Business Requirement/Business rules	Data Source/ Database Location	Format	Length
DE1	Record Type	Constant I	1. Report 'I'	n/a	Alpha	1
DE2	Serving Division	Three-digit state-assigned Division number that identifies the division, center or agency that provided the course (or the resource to the course) to the students	<ol style="list-style-type: none"> <li>1. Report the numbers before the dash if populated on the section being reported                             <ol style="list-style-type: none"> <li>a. Left pad with zeros to make 3-digits if applicable</li> </ol> </li> <li>2. If NULL, report the State District Number                             <ol style="list-style-type: none"> <li>a. Left pad with zeros to make 3-digits if applicable</li> </ol> </li> </ol>	Scheduling & Courses > Section Information > Serving Division-School  OR  School & District Settings > District Information > State District Number  Section.serviceDistrict	Alphanumeric	3
DE3	Serving School	Four-digit state-assigned School number that identifies the school, center, program, or placement that provided the course (or the resource to the course) to the students	<ol style="list-style-type: none"> <li>1. Report the numbers after the dash if populated on the section being reported                             <ol style="list-style-type: none"> <li>a. Left pad with zeros to make 4-digits if applicable</li> </ol> </li> <li>2. If NULL, report the State School Number                             <ol style="list-style-type: none"> <li>a. Left pad with zeros to make 4-digits if applicable</li> </ol> </li> </ol>	Scheduling & Courses > Section Information > Serving Division-School  OR  School & District Settings > School > State School Number  Section.serviceDistrict	Alphanumeric	4

CAMPUS STATE SPECIFIC LOCALIZATIONS - VA - MASTER SCHEDULE (MSC)

DE4	Section ID	<p>A locally defined number that identifies a particular section. When coupled with the division and school, Section ID creates a unique identifier for the section.</p> <p>Section should be the highest level taught during that section. If no sequence, use the section with the most students.</p>	<ol style="list-style-type: none"> <li>1. Determine if CTE courses are connected. The Perkins Code must be populated on both courses to be eligible:             <ol style="list-style-type: none"> <li>a. When the Connected Section data begins with an alpha report connected section data as is</li> <li>b. When the Connected Section data begins with a number report connected section data with the same combination as the Section ID logic but use Connected Section as the Section ID : D + District Number-School Number-Course Number-Connected Section                 <ol style="list-style-type: none"> <li>i. The first position will default to <b>D</b></li> <li>ii. Next report from Resources &gt; District Info &gt; *State District Number, with a dash separating this number from the next number (School number)</li> <li>iii. Next report from Resources &gt; School &gt; *State School Number, with a dash separating this number from the next number (Course number)</li> <li>iv. Next report from Course &gt; Number (local number), with a dash separating this number from the next number (Section number)</li> <li>v. Next report from Section &gt; Connected Section</li> </ol> </li> </ol> </li> </ol>	<p>Scheduling &amp; Courses &gt; Section Information &gt; Connected Section</p> <p>Section.number</p>	Alphanumeric	Max 30
DE5	Connected Section ID			<p>Scheduling &amp; Courses &gt; Section Information &gt; Section Number</p>	A/N	Max 3

A locally defined number that identifies a particular section of a course. When coupled with the division and school, Section ID creates a unique identifier for the section.

The Connected Section should be the lowest level taught during that section. If no sequence, use the section with the least students.

1. Report Section ID with the following combination : D + District Number-School Number-Course Number-Section Number (D014-1234-123456789-123)
  - a. The first position will default to **D**
  - b. Next report from Resources > District Info > \*State District Number, with a dash separating this number from the next number (School number)
  - c. Next report from Resources > School > \*State School Number, with a dash separating this number from the next number (Course number)
  - d. Next report from Course > Number (local number), with a dash separating this number from the next number (Section number)
  - e. Next report from Section > Section Number.

Report Section ID with the following combination : D + District Number-School Number-Course Number-Section Number (D014-1234-123456789-123)

1. The first position will default to **D**
2. Next report from School & District Settings > District Info > \*State District Number, with a dash separating this number from the next number (School number)
3. Next report from School & District Settings > School > \*State School Number, with a dash separating this number from the next number (Course number)
4. Next report from Scheduling & Courses > Course Information > Number (local number), with a dash separating this number from the next number (Section number)
5. Next report from Scheduling & Courses > Section Information > Section Number.

Section.number

CAMPUS STATE SPECIFIC LOCALIZATIONS - VA - MASTER SCHEDULE (MSC)

---

## J Record

### Description

#### Summary

The J record is a part of the VA Master Schedule Extract

#### Functional Requirements

#### Reporting Population

J Records report for teachers of Co-Op course sections

1. Report only on courses that have a course Type code = J MSC
  - a. Report distinct number of students assigned to the teacher being reported
    - i. If a student is rostered into more than 1 course with the same teacher, only report the student once. This calculation is the total number of students participating in a work based Co-Op program by teacher.

#### Reporting Population and Business Rules - J Record

#	Requirement
R1	An option exists in the Master Schedule Extract to generate J Records
R2	The J Records are generated from a shared Master Schedule Extract Editor
R2.BR1	The J Records can be generated with an other combination of MSC Records
R	The J Records will report in accordance with the Report Element Layout and Business Rules

Report Data Elements - I Record

#	Data Element	State Description	Business Requirement/Business rules	Data Source/ Database Location	Format	Length
DE1	Record Type	Constant J	1. Report 'J'	n/a	Alpha	1
DE2	Serving Division	Three-digit state-assigned Division number that identifies the division, center or agency that provided the course (or the resource to the course) to the students	<ol style="list-style-type: none"> <li>1. Report the numbers before the dash if populated on the section being reported                             <ol style="list-style-type: none"> <li>a. Left pad with zeros to make 3-digits if applicable</li> </ol> </li> <li>2. If NULL, report the State District Number                             <ol style="list-style-type: none"> <li>a. Left pad with zeros to make 3-digits if applicable</li> </ol> </li> </ol>	Scheduling & Courses > Section Information > Serving Division-School  OR  School & District Settings > District Information > State District Number  Section.serviceDistrict	Alphanumeric	Max 3

CAMPUS STATE SPECIFIC LOCALIZATIONS - VA - MASTER SCHEDULE (MSC)

DE3	Serving School	Four-digit state-assigned School number that identifies the school, center, program, or placement that provided the course (or the resource to the course) to the students	<ol style="list-style-type: none"> <li>Report the numbers after the dash if populated on the section being reported                             <ol style="list-style-type: none"> <li>Left pad with zeros to make 4-digits if applicable</li> </ol> </li> <li>If NULL, report the State School Number                             <ol style="list-style-type: none"> <li>Left pad with zeros to make 4-digits if applicable</li> </ol> </li> </ol>	Scheduling & Courses > Section Information > Serving Division-School  OR  School & District Settings > School Information > State School Number  Section.serviceDistrict	Alphanumeric	Max 4
DE4	Local Provider Id	Locally defined identification number must be unique within the division (i.e. employee id, teacher id, tax id) Do not use SSN for this Id	<ol style="list-style-type: none"> <li>Report local staff number</li> <li>Else, blank</li> </ol>	Census > People > Demographics > Local Staff Number  person.staffNumber	Alphanumeric	Max 20
DE5	Number of Students in Co-op Program	Number of Co-op students overseen by the Local Provider during the school year	<ol style="list-style-type: none"> <li>If Course Type code = J MSC, count the distinct number of students rostered for each teacher associated with any J MSC course</li> <li>Leading Zero's must be included</li> </ol>	Scheduling & Courses > Course Information > Course Type	Numeric	2

CAMPUS STATE SPECIFIC LOCALIZATIONS - VA - MASTER SCHEDULE (MSC)

DE6	Avg. # of Minutes	Average length in Minutes of the Teacher's Co-op Periods	<p>For the teacher being reported, report the Average length in Minutes of the Teacher's Co-op Periods</p> <ol style="list-style-type: none"> <li>1. Look to Course Type = J MSC.</li> <li>2. Find the teacher of the section. Count how many sections the teacher is teaching where Setting = Cooperative Education. (this is reported by teacher and their coop sections)             <ol style="list-style-type: none"> <li>a. Sum the minutes of each period(s) that the Coop section(s) meet. Divide the minutes by the number of J MSC sections the teacher teaches for the Minutes of J MSC Period. Ex : Teacher has 2 J MSC periods. One period is 50 minutes, the other is 40. <math>90/2 = 45</math> Minutes of J MSC Period</li> </ol> </li> <li>3. If the teacher has only 1 J MSC section, report the minutes of the period that section meets.</li> <li>4. Must be length of 2, if there is a decimal in the Minutes, round down. Ex: 91.23 minutes = 91</li> </ol>	Scheduling & Courses > Course Information > Course Type	Numeric	2
-----	-------------------	--	---	---	---------	---

			<ol style="list-style-type: none"><li>1. <del>Find each course section a teacher is an active teacher where Course Type = Co-Op</del></li><li>2. <del>Use the section schedule placement for each section to determine period schedule(s) the course section is assigned to</del><ol style="list-style-type: none"><li>a. <del>Sum the total number of instructional minutes for that period based on the instructional days that period schedule is assigned to on the days tab.</del><ol style="list-style-type: none"><li>i. <del>If the section is assigned to more than 1 period schedule, sum the total number of minutes from each period schedule</del></li></ol></li><li>b. <del>Sum the total number of instructional minutes for all Co-Op courses for that teacher</del></li></ol></li><li>3. <del>Use the section schedule placement for each section to determine terms the course section occurs</del><ol style="list-style-type: none"><li>a. <del>Count the number of instructional days between the term start and end dates based on the terms tab and section schedule placement</del></li><li>b. <del>Sum the total instructional days for all sections for that teacher</del></li></ol></li><li>4. <del>Divide the sum of instructional minutes for all sections by the sum of instructional days for all sections for that teacher</del></li></ol>		
--	--	--	---	--	--